

Color: ■ light gray

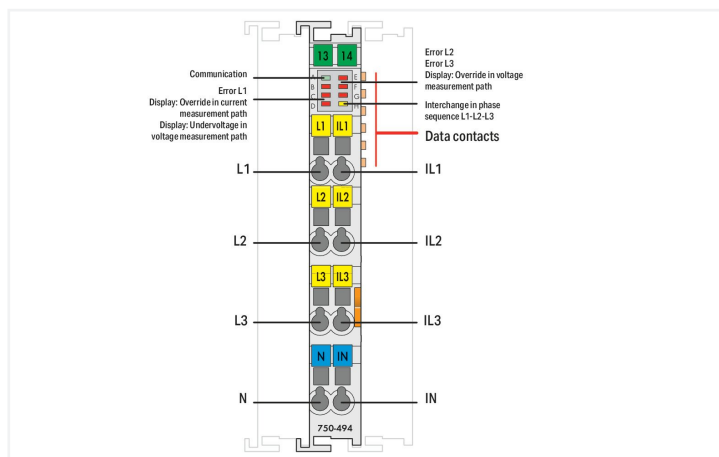
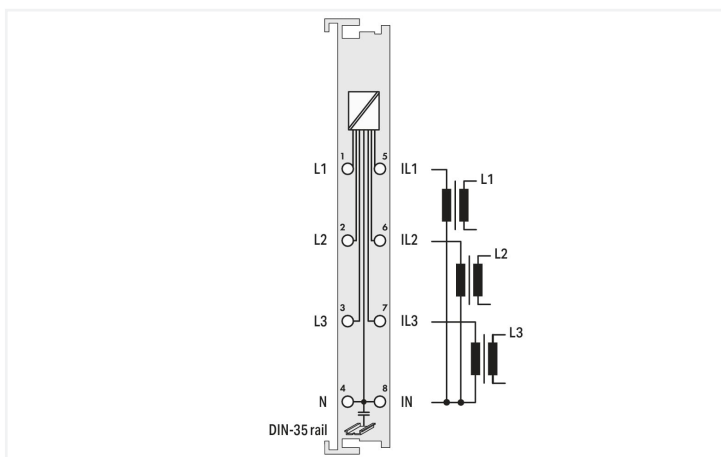

The 750-494 3-Phase Power Measurement Module measures electrical data in a three-phase supply network.

The voltage is measured via network connection to clamping points L1, L2, L3 and N.

The current of the three phases is fed to IL1, IL2, IL3, and IN via current transformers.

The 3-phase power measurement module transmits all metrics (e.g., reactive/apparent/effective power, energy consumption, power factor, phase angle, frequency, over-/undervoltage) directly to the process image, without requiring high computing power from the controller. Both comprehensive metrics and harmonic analysis up to the 41st harmonic permit extensive network analysis via the fieldbus. These metrics enable the operator to optimize supply to a drive or machine, protecting the system from damage and failure. The four-quadrant display indicates the load type (inductive, capacitive) and whether it is an energy consumer or producer.

Technical data

Number of measurement inputs	6 (3 voltage measurement inputs, 3 current measurement inputs)
Signal type	Power measurement
Signal form	Any periodic signals (considering the threshold frequencies)
Resolution [bit]	24 bits
Data width	2 x 128-bit data; 2 x 64-bit control/status
Voltage path input resistance (typ.)	1072 kΩ
Current path input resistance (typ.)	5 mΩ
Reference for measurement error	AC current/voltage
Measurement error (reference temperature)	25 °C
Measurement error, deviation (max.) from the upper-range value	0.5 %
Measurement current (max.)	5 A
Measurement cycle time	Adjustable for the arithmetic mean value, min./max. values
Frequency range (mains frequency)	45 ... 65 Hz
Frequency range (harmonics analysis)	0 ... 3300 Hz
Limit frequency	15.9 kHz
Rated voltage	$U_{LN} = 277 \text{ VAC/DC}; U_{LL} = 480 \text{ VAC}$

Technical data

Calculated values	Line-to-line voltage, power output, energy, power factors, mains frequency, harmonic analysis (up to the 41st harmonic), THD
Measurement components	Evaluating
Measurement method	True RMS measurement
Configuration options	WAGO-I/O-CHECK CODESYS Library e!COCKPIT
Supply voltage (system)	5 VDC; via data contacts
Current consumption (5 V system supply)	100 mA
Isolation	4 kV system/field
Rated surge voltage	4 kV
Indicators	LED (A) green: Communication; LED (B-G) red: Error L1, Override in Current Measurement Path (display), Undervoltage in Voltage Measurement Path (display), Error L2, Error L3, Override in Voltage Measurement Path (display); LED (H) yellow: Interchange in Phase Sequence L1-L2-L3

Connection data

Connection technology: inputs/outputs	8 x CAGE CLAMP®
Connection type 1	Inputs/outputs
Solid conductor	0.08 ... 2.5 mm ² / 28 ... 14 AWG
Fine-stranded conductor	0.08 ... 2.5 mm ² / 28 ... 14 AWG
Strip length	8 ... 9 mm / 0.31 ... 0.35 inches

Physical data

Width	12 mm / 0.472 inches
Height	100 mm / 3.937 inches
Depth	67.8 mm / 2.669 inches
Depth from upper-edge of DIN-rail	60.6 mm / 2.386 inches

Mechanical data

Mounting type	DIN-35 rail
---------------	-------------

Material data

Color	light gray
Housing material	Polycarbonate; polyamide 6.6
Fire load	0.955 MJ
Weight	48.5 g
Conformity marking	CE

Environmental requirements

Ambient temperature (operation)	0 ... +55 °C
Ambient temperature (storage)	-40 ... +85 °C
Protection type	IP20
Pollution degree	2
Operating altitude	0 ... 2000 m / 0 ... 6562 ft
Mounting position	horizontal (standing/lying); vertical
Relative humidity (without condensation)	95 %
Vibration resistance	4g per IEC 60068-2-6
Shock resistance	15g per IEC 60068-2-27
EMC immunity to interference	per EN 61000-6-2
EMC emission of interference	per EN 61000-6-3
Exposure to pollutants	per IEC 60068-2-42 and IEC 60068-2-43
Permissible H ₂ S contaminant concentration at a relative humidity 75 %	10 ppm

Environmental requirements

Permissible SO₂ contaminant concentration at a relative humidity 75 % 25 ppm

Commercial data

Product Group	15 (I/O System)
eCl@ss 10.0	27-24-26-05
eCl@ss 9.0	27-24-26-05
ETIM 8.0	EC001601
ETIM 7.0	EC001601
PU (SPU)	1 pcs
Packaging type	Box
Country of origin	DE
GTIN	4050821548249
Customs tariff number	85389099990

Environmental Product Compliance

CAS-No.	1303-86-2 1317-36-8 7439-92-1
REACH Candidate List Substance	Diboron trioxide Lead Lead monoxide
RoHS Compliance Status	Compliant,With Exemption
RoHS Exemption	6(c) 7(a) 7(c)-I 7(c)-II
SCIP notification number (Bulgaria)	4bed68c7-6a25-4798-b488-2fd88c66f5fd
SCIP notification number (Czech Republic)	96a72ec3-b906-4f49-9abf-72aa9f175e09

Approvals / Certificates

General approvals



Approval	Standard	Certificate Name
UL Underwriters Laboratories Inc. (ORDINARY LOCATIONS)	UL 508	E175199 Sec.1

Approvals for marine applications



Approval	Standard	Certificate Name
BSH Bundesamt fuer Seeschifffahrt und Hydrographie	-	1104
PRS Polski Rejestr Statków	-	TE/2236/880590/19
RINA RINA Germany GmbH	-	ELE343521XG001

Approvals for hazardous areas



Approval	Standard	Certificate Name
ATEX TUEV Nord Cert GmbH	EN 60079-0	TUEV14ATEX148929X (II 3 G Ex ec IIC T4 Gc)
CCCEX CQST/CNEX	CNCA-C23-01	2020312310000213 (Ex ec IIC T4 Gc)
EAC Brjansker Zertifizierungsstelle	TP TC 012/2011	EAC RU C-DE.AM02. B.00163/19 (2Ex nA IIC T4 Gc X)

Approvals for hazardous areas

Approval	Standard	Certificate Name
IECEX TUEV Nord Cert GmbH	IEC 60079-0	IECEX TUN 14.0035 X (Ex ec IIC T4 Gc)
INMETRO TUV Rheinland do Brasil Ltda.	IEC 60079-0	BR-Ex_TUV 12.1297 X
UKEx WAGO GmbH & Co. KG	EN 60079-0	UKCA_WA GO22UKEX003X_ec
UL Underwriters Laboratories Inc. (HAZARDOUS LOCATIONS)	UL 121201	E198726 Sec.1

Downloads

Environmental Product Compliance

Compliance Search

Environmental Product Compliance
750-494/000-001



Documentation

Manual

System Manual WAGO I/O System 750/753 V 3.3.3 29.08.2023 pdf 8512.61 KB

System Manual Series 750/753

Product Manual 3-Phase Power Measurement Module V 1.2.0 pdf 4656.07 KB

System Description

750/753 Series I/O-System – General Product Information pdf 953.35 KB

Overview on WAGO-I/O-SYSTEM 750 approvals pdf 770.48 KB

Bid Text

750-494/000-001 19.02.2019 xml 6.03 KB

750-494/000-001 20.10.2017 doc 30.50 KB

Instruction Leaflet

CCC Ex (Additional information) 26.04.2023 pdf 159.76 KB

Application Notes

Application Note e!COCKPIT

e!COCKPIT Application Note WagoAppPower-Measurement 2021-11-08 06.12.2021 pdf 930.71 KB

CAD/CAE-Data

CAD data

2D/3D Models 750-494/000-001

CAE data

EPLAN Data Portal 750-494/000-001

WSCAD Universe 750-494/000-001

ZUKEN Portal 750-494/000-001

Runtime Software

Firmware			
0750-0494, 3-Phasen-Leistungsmessung	V 06 07.06.2022	zip 175.60 KB	

Libraries

Library			
Bausteinbeschreibung für die PowerMeasurement_494_02.lib	4.1.2 23.06.2020	zip 1828.54 KB	

1 Compatible Products

1.1 Optional Accessories

1.1.1 Current transformer

1.1.1.1 Current transformer terminal block



Item No.: 2007-8873

Compact terminal block; for current and voltage transformers; 6,00 mm²; multicoloured

Item No.: 2007-8875

Compact terminal block; for current transformer circuit; 6,00 mm²; multicoloured

1.1.1.2 Plug-in current transformer



Item No.: 855-305/300-501

Plug-in current transformer; Primary rated current 300 A; Secondary rated current: 5 A; Rated power: 5 VA; Accuracy class: 1

Item No.: 855-405/750-501

Plug-in current transformer; Primary rated current 750 A; Secondary rated current: 5 A; Rated power: 5 VA; Accuracy class: 1

Item No.: 855-305/100-201

Plug-in current transformer; Primary rated current: 100 A; Secondary rated current: 5 A; Rated power: 2.5 VA; Accuracy class: 1

Item No.: 855-505/1000-1001

Plug-in current transformer; Primary rated current: 1000 A; Secondary rated current: 5 A; Rated power: 10 VA; Accuracy class: 1



Item No.: 855-305/150-501

Plug-in current transformer; Primary rated current: 150 A; Secondary rated current: 5 A; Rated power: 5 VA; Accuracy class: 1

Item No.: 855-605/1500-501

Plug-in current transformer; Primary rated current: 1500 A; Secondary rated current: 5 A; Rated power: 5 VA; Accuracy class: 1

Item No.: 855-305/200-501

Plug-in current transformer; Primary rated current: 200 A; Secondary rated current: 5 A; Rated power: 5 VA; Accuracy class: 1

Item No.: 855-805/2000-1001

Plug-in current transformer; Primary rated current: 2000 A; Secondary rated current: 5 A; Rated power: 10 VA; Accuracy class: 1



Item No.: 855-305/250-501

Plug-in current transformer; Primary rated current: 250 A; Secondary rated current: 5 A; Rated power: 5 VA; Accuracy class: 1

Item No.: 855-405/250-501

Plug-in current transformer; Primary rated current: 250 A; Secondary rated current: 5 A; Rated power: 5 VA; Accuracy class: 1

Item No.: 855-1005/2500-1001

Plug-in current transformer; Primary rated current: 2500 A; Secondary rated current: 5 A; Rated power: 10 VA; Accuracy class: 1

Item No.: 855-305/400-1001

Plug-in current transformer; Primary rated current: 400 A; Secondary rated current: 5 A; Rated power: 10 VA; Accuracy class: 1



Item No.: 855-505/400-1001

Plug-in current transformer; Primary rated current: 400 A; Secondary rated current: 5 A; Rated power: 10 VA; Accuracy class: 1

Item No.: 855-405/400-501

Plug-in current transformer; Primary rated current: 400 A; Secondary rated current: 5 A; Rated power: 5 VA; Accuracy class: 1

Item No.: 855-305/050-103

Plug-in current transformer; Primary rated current: 50 A; Secondary rated current: 5 A; Rated power: 1.25 VA; Accuracy class: 3

Item No.: 855-305/060-101

Plug-in current transformer; Primary rated current: 60 A; Secondary rated current: 5 A; Rated power: 1.25 VA; Accuracy class: 1



Item No.: 855-305/600-1001

Plug-in current transformer; Primary rated current: 600 A; Secondary rated current: 5 A; Rated power: 10 VA; Accuracy class: 1

Item No.: 855-505/600-1001

Plug-in current transformer; Primary rated current: 600 A; Secondary rated current: 5 A; Rated power: 10 VA; Accuracy class: 1

Item No.: 855-305/075-201

Plug-in current transformer; Primary rated current: 75 A; Secondary rated current: 5 A; Rated power: 2.5 VA; Accuracy class: 1

Item No.: 855-505/800-1001

Plug-in current transformer; Primary rated current: 800 A; Secondary rated current: 5 A; Rated power: 10 VA; Accuracy class: 1

1.1.1.3 Split-core current transformer



Item No.: 855-5005/1000-000
Split-core current transformer; Primary rated current: 1000 A; Secondary rated current: 5 A; Rated power: 0.5 VA; Accuracy class: 0.5; Cable length: 3 m



Item No.: 855-5105/1000-000
Split-core current transformer; Primary rated current: 1000 A; Secondary rated current: 5 A; Rated power: 0.5 VA; Accuracy class: 0.5; Cable length: 3 m



Item No.: 855-4005/150-101
Split-core current transformer; Primary rated current: 150 A; Secondary rated current: 5 A; Rated power: 1 VA; Accuracy class: 1; Cable length: 0.5 m



Item No.: 855-4105/250-101
Split-core current transformer; Primary rated current: 250 A; Secondary rated current: 5 A; Rated power: 1 VA; Accuracy class: 1; Cable length: 0.5 m



Item No.: 855-5005/400-001
Split-core current transformer; Primary rated current: 400 A; Secondary rated current: 5 A; Rated power: 0.5 VA; Accuracy class: 1; Cable length: 3 m



Item No.: 855-4105/400-101
Split-core current transformer; Primary rated current: 400 A; Secondary rated current: 5 A; Rated power: 1 VA; Accuracy class: 1; Cable length: 0.5 m



Item No.: 855-5005/600-000
Split-core current transformer; Primary rated current: 600 A; Secondary rated current: 5 A; Rated power: 0.5 VA; Accuracy class: 0.5; Cable length: 3 m

1.1.2 DIN-rail

1.1.2.1 Mounting accessories



Item No.: 210-196
Aluminum carrier rail; 35 x 8.2 mm; 1.6 mm thick; 2 m long; unslotted; similar to EN 60715; silver-colored



Item No.: 210-198
Copper carrier rail; 35 x 15 mm; 2.3 mm thick; 2 m long; unslotted; according to EN 60715; copper-colored



Item No.: 210-508
Steel carrier rail; 35 x 15 mm; 1.5 mm thick; 2 m long; slotted; galvanized; similar to EN 60715; silver-colored



Item No.: 210-197
Steel carrier rail; 35 x 15 mm; 1.5 mm thick; 2 m long; slotted; similar to EN 60715; silver-colored



Item No.: 210-506
Steel carrier rail; 35 x 15 mm; 1.5 mm thick; 2 m long; unslotted; galvanized; similar to EN 60715; silver-colored



Item No.: 210-114
Steel carrier rail; 35 x 15 mm; 1.5 mm thick; 2 m long; unslotted; similar to EN 60715; silver-colored



Item No.: 210-118
Steel carrier rail; 35 x 15 mm; 2.3 mm thick; 2 m long; unslotted; according to EN 60715; silver-colored



Item No.: 210-115
Steel carrier rail; 35 x 7.5 mm; 1 mm thick; 2 m long; slotted; according to EN 60715; "Hole width 18 mm; silver-colored



Item No.: 210-112
Steel carrier rail; 35 x 7.5 mm; 1 mm thick; 2 m long; slotted; according to EN 60715; "Hole width 25 mm; silver-colored



Item No.: 210-504
Steel carrier rail; 35 x 7.5 mm; 1 mm thick; 2 m long; slotted; galvanized; according to EN 60715; silver-colored



Item No.: 210-113
Steel carrier rail; 35 x 7.5 mm; 1 mm thick; 2 m long; unslotted; according to EN 60715; silver-colored



Item No.: 210-505
Steel carrier rail; 35 x 7.5 mm; 1 mm thick; 2 m long; unslotted; galvanized; according to EN 60715; silver-colored

1.1.3 Marking

1.1.3.1 Group marker carrier



Item No.: 750-107
Group marker carrier

1.1.3.2 Marker



Item No.: 2009-145/000-006
Mini-WSB Inline; for Smart Printer; 1700 pieces on roll; stretchable 5 - 5.2 mm; plain; snap-on type; blue



Item No.: 2009-145/000-007
Mini-WSB Inline; for Smart Printer; 1700 pieces on roll; stretchable 5 - 5.2 mm; plain; snap-on type; gray



Item No.: 2009-145/000-023
Mini-WSB Inline; for Smart Printer; 1700 pieces on roll; stretchable 5 - 5.2 mm; plain; snap-on type; green



Item No.: 2009-145/000-012
Mini-WSB Inline; for Smart Printer; 1700 pieces on roll; stretchable 5 - 5.2 mm; plain; snap-on type; orange



Item No.: 2009-145/000-005
Mini-WSB Inline; for Smart Printer; 1700 pieces on roll; stretchable 5 - 5.2 mm; plain; snap-on type; red



Item No.: 2009-145/000-024
Mini-WSB Inline; for Smart Printer; 1700 pieces on roll; stretchable 5 - 5.2 mm; plain; snap-on type; violet



Item No.: 2009-145
Mini-WSB Inline; for Smart Printer; 1700 pieces on roll; stretchable 5 - 5.2 mm; plain; snap-on type; white



Item No.: 2009-145/000-002
Mini-WSB Inline; for Smart Printer; 1700 pieces on roll; stretchable 5 - 5.2 mm; plain; snap-on type; yellow

1.1.3.2 Marker



Item No.: 248-501/000-006
Mini-WSB marking card; as card; not stretchable; plain; snap-on type; blue

Item No.: 248-501/000-007
Mini-WSB marking card; as card; not stretchable; plain; snap-on type; gray

Item No.: 248-501/000-023
Mini-WSB marking card; as card; not stretchable; plain; snap-on type; green

Item No.: 248-501/000-017
Mini-WSB marking card; as card; not stretchable; plain; snap-on type; light green



Item No.: 248-501/000-012
Mini-WSB marking card; as card; not stretchable; plain; snap-on type; orange

Item No.: 248-501/000-005
Mini-WSB marking card; as card; not stretchable; plain; snap-on type; red

Item No.: 248-501/000-024
Mini-WSB marking card; as card; not stretchable; plain; snap-on type; violet

Item No.: 248-501
Mini-WSB marking card; as card; not stretchable; plain; snap-on type; white



Item No.: 248-501/000-002
Mini-WSB marking card; as card; not stretchable; plain; snap-on type; yellow

1.1.3.3 Marker carrier



Item No.: 750-103
Group marker carrier

1.1.4 Power tap

1.1.4.1 Power tap



Item No.: 855-8003
Power tap; with fuse; 10 mm² (8 AWG) - 16 mm² (6 AWG); Phase

Item No.: 855-8001
Power tap; with fuse; 2,5 mm² (12 AWG) - 6 mm² (10 AWG); Phase

Item No.: 855-8004
Power tap; without fuse; 10 mm² (8 AWG) - 16 mm² (6 AWG); N-conductor

Item No.: 855-8002
Power tap; without fuse; 2,5 mm² (12 AWG) - 6 mm² (10 AWG); N-conductor

1.1.5 Shield termination

1.1.5.1 Shield clamping saddles



Item No.: 790-108
Shield clamping saddle; 11 mm wide; diameter of compatible conductor; 3 ... 8 mm

Item No.: 790-208
Shield clamping saddle; 12,4 mm wide; 3 ... 8 mm

Item No.: 790-116
Shield clamping saddle; 19 mm wide; diameter of compatible conductor; 7 ... 16 mm

Item No.: 790-216
Shield clamping saddle; 21,8 mm wide; 6 ... 16 mm



Item No.: 790-124
Shield clamping saddle; 27 mm wide; diameter of compatible conductor; 6 ... 24 mm

Item No.: 790-220
Shield clamping saddle; 30 mm wide; 6 ... 20 mm

Item No.: 790-140
Shield clamping saddle; diameter of compatible conductor

1.1.6 System enclosure

1.1.6.1 System enclosure

**Item No.: 850-825**

IP65 enclosure; Aluminium (RAL 7032);
WxHxD (160x100x160 mm); 9 x M12, 4 x
M20

**Item No.: 850-826**

IP65 enclosure; Aluminium (RAL 7032);
WxHxD (240x100x160 mm); 4 x M20, 4 x
M16, 14 x M12 cable grip

**Item No.: 850-827**

IP65 enclosure; Aluminium (RAL 7032);
WxHxD (320x100x160 mm); 4 x M20, 8 x
M16, 17 x M12 cable grip

**Item No.: 850-828**

IP65 enclosure; Aluminium (RAL 7032);
WxHxD (480x100x160 mm); 4 x M20, 10 x
M16, 35 x M12 cable grip

**Item No.: 850-826/002-000**

IP65 enclosure; Aluminium (RAL 7035);
WxHxD (240x100x160 mm); 4 x M20, 4 x
M16, 14 x M12 cable grip

**Item No.: 850-827/002-000**

IP65 enclosure; Aluminium (RAL 7035);
WxHxD (320x100x160 mm); 4 x M20, 8 x
M16, 17 x M12 cable grip

**Item No.: 850-828/002-000**

IP65 enclosure; Aluminium (RAL 7035);
WxHxD (480x100x160 mm); 4 x M20, 10 x
M16, 35 x M12 cable grip

**Item No.: 850-834**

IP65 enclosure; Polyester (RAL 7032); Wx-
HxD (164x100x164 mm); 9 x M12, 4 x M20

**Item No.: 850-835**

IP65 enclosure; Polyester (RAL 7032); Wx-
HxD (244x100x164 mm); 4 x M20, 4 x
M16, 14 x M12 cable grip

**Item No.: 850-836**

IP65 enclosure; Polyester (RAL 7032);
WxHxD (324x100x164 mm); 4 x M20, 8 x
M16, 17 x M12 cable grip

**Item No.: 850-814/002-000**

IP65 enclosure; Sheet steel (RAL 7035);
WxHxD (200x120x200 mm); without flan-
ge plate

**Item No.: 850-815/002-000**

IP65 enclosure; Sheet steel (RAL 7035);
WxHxD (300x120x200 mm); without flan-
ge plate

**Item No.: 850-816/002-000**

IP65 enclosure; Sheet steel (RAL 7035);
WxHxD (400x120x200 mm); without flan-
ge plate

**Item No.: 850-817/002-000**

IP65 enclosure; Sheet steel (RAL 7035);
WxHxD (600x120x200 mm); without flan-
ge plate