

REWIRING INSTRUCTION



For 2-lamp luminaires to AC mains direct wiring for operation with LEDVANCE LED TUBE T8 EM, UNIVERSAL or LEDVANCE LED TUBE T5 AC

Rewiring of 2-lamp Luminaires

Rewiring must be executed by a qualified electrician.

Luminaire to be rewired (ECG mounting already removed)



Tools needed: wire cutter, wire stripper, different screwdrivers

New wires must comply with latest version of EN 50525 and EN 60598-1, have a minimum cross section of 0,4 mm² and the isolation have a nominal thickness of 0,5 mm.

Material included in conversion kit



Content conversion kit:

- 6 WAGO connectors
- 4 adhesive sockets for cable ties
- 4 cable ties
- New blank name plate for luminaire (to be fixed clearly visible and permanently on the luminaire)
- Pre-wired microfuse (T2A 250V)

1. General Work Steps

Direct wiring circuit diagram of a 2-lamp luminaire on AC mains

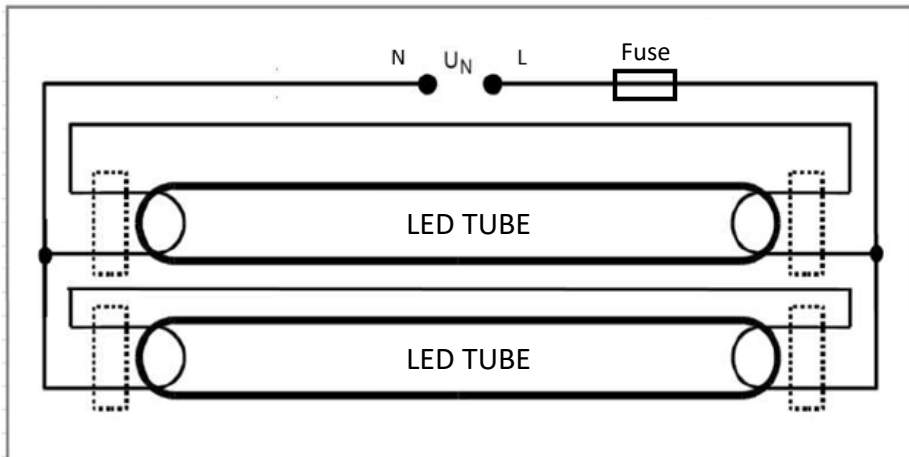

Remove wiring from ECG step by step and re-connect as prescribed below



Step 1: Connect mains line "L" to fuse with one wire using a WAGO connector

Step 2: Connect second fuse line to both right lamp holders. Pay attention to correct connection of all ECG clamps within the following steps.

Step 3: Connect lines of left and right lamp holders for lamp 1 and 2.

Step 4: Connect both left lamp holders to neutral line „N“. Use WAGO connectors if needed.



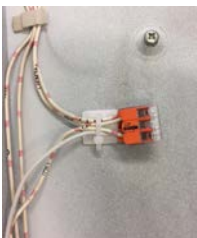

Step 5: Remove ECG.

Step 6: Fix all wires with adhesive sockets and cable ties.



1. General Work Steps

Step 7: After CE conformity test, fill in and fix new name plate clearly visible and permanently on luminaire while removing or pasting over old name plate.

Umrüster/Installer/Installateur: _____ _____ _____	CE  
Datum/Date: _____	
Leuchtentyp/Luminaire type: _____	
230V~ / 50Hz / max. _____ W / <input type="checkbox"/> G13 <input type="checkbox"/> G5	
<small>Nur geeignet für LED-Konversions-Röhren des Typs LEDVANCE LED TUBE T8/T5. Only suitable for use with LED conversion tubes type LEDVANCE LED TUBE T8/T5. Luminaire converti en câblage direct pour Tubes LED compatibles uniquement type LEDVANCE LED TUBE T8/T5.</small>	

Step 8: Conduct final visual inspection of all components and check if all wires have been fixed tightly inside of the WAGO connectors. Cables should not be pinched during the mounting of the luminaire. Defect parts must be repaired or replaced.

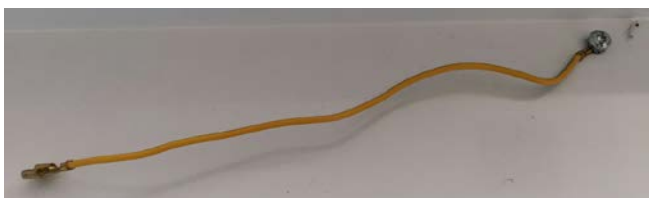

If needed, re-connect earth conductor (PE)



2. Wiring examples with typical ECG

Remove wiring from ECG step by step and re-connect as prescribed below



Step 1: Connect mains line "L" to fuse with one wire



1. ECG with 7 connectors (e.g. Siemens, OSRAM, BAG)

1.1 Siemens ECG

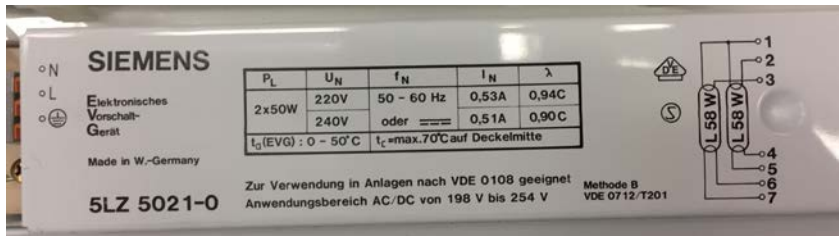

Step 2 Connect second fuse line to line „7“ and „5“

Step 3: Connect line „6“ to line „3“

Step 4: Connect line „4“ to line „2“

Step 5: Connect line „1“ to line „N“

Further steps according to general work steps.

2. Wiring examples with typical ECG

1.2 OSRAM ECG

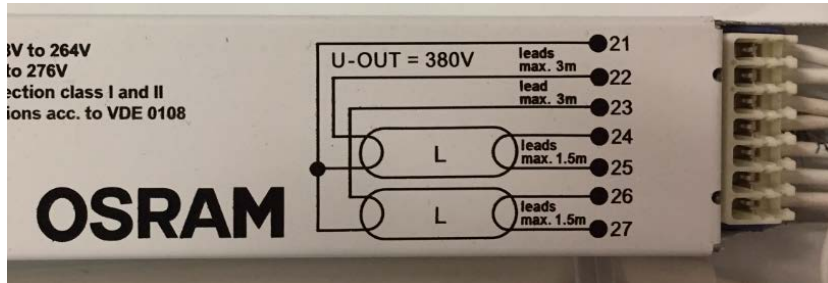

Step 2: Connect second fuse line to line „24“ and „26“

Step 3: Connect line „25“ to line „22“

Step 4: Connect line „27“ to line „23“

Step 5: Connect line „21“ to line „N“

Further steps according to general work steps.

1.3 BAG ECG

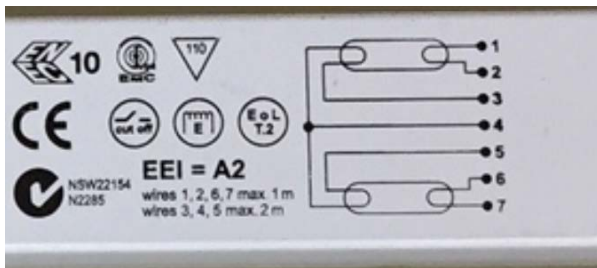

Step 2: Connect second fuse line to line „1“ and „7“

Step 3: Connect line „6“ to line „5“

Step 4: Connect line „3“ to line „2“

Step 5: Connect line „4“ to line „N“

Further steps according to general work steps.

2. Wiring examples with typical ECG

2. ECG with 6 connectors (e.g. Philips, Tridonic)

2.1 Philips ECG

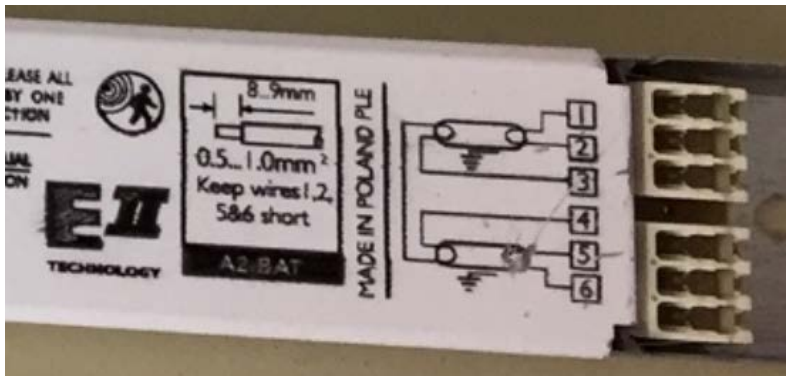

Step 2: Connect second fuse line to line „1“ and „6“

Step 3: Connect line „2“ to line „3“

Step 4: Connect line „4“ to line „5“

Step 5: Connect both connection lines of left lamp holders to „N“

Further steps according to general work steps.

2.2 Zumtobel/ Tridonic ECG



Step 2: Connect second fuse line to line „11“ and „16“

Step 3: Connect line „12“ to line „13“

Step 4: Connect line „14“ to line „15“

Step 5: Connect both connection lines of left lamp holders to „N“

Further steps according to general work steps.

3. General Work Steps CCG Luminaire

Circuit diagram of a double-flame luminaire with traditional CCG, fluorescent lamp and starter

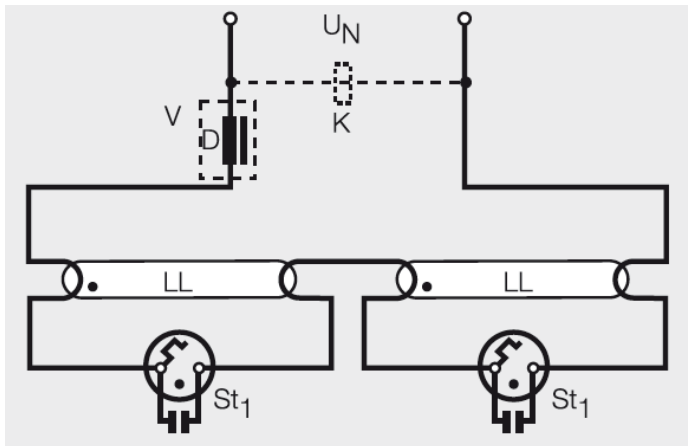

Remove wiring from CCG step by step and connect as described, if applicable remove compensation capacitor as well

Circuit diagram of a rewired, double-flame luminaire with LED tubes on AC mains

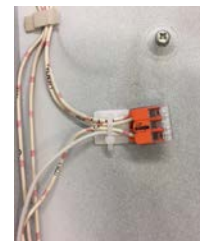
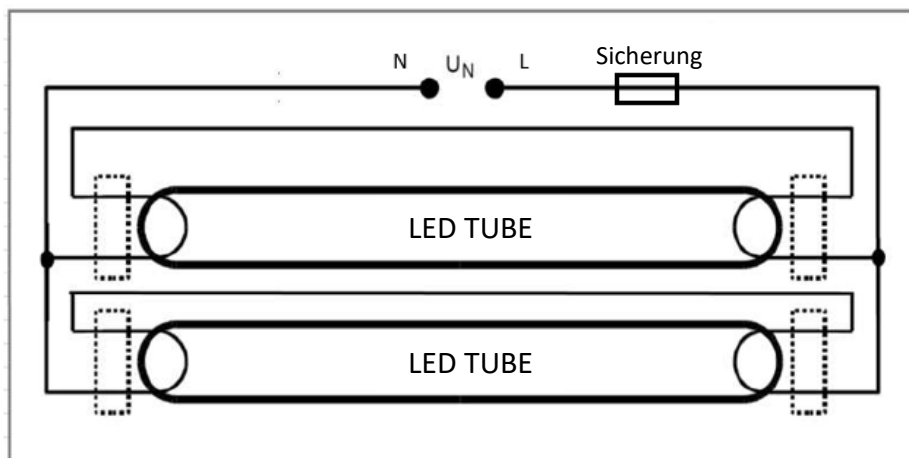

Step 1: Connect mains line “L” to fuse with one wire using a WAGO connector.

Step 2: Connect second line of fuse in parallel with a lamp holder of one lamp (see circuit diagram above). It is recommended to use the side that had been previously connected to the CCG.

Step 3: Remove starter holder to establish a connection between the right and left lamp holder

Step 4: Connect cables leading to starter holder using a WAGO connector.

Step 5: Remove CCGs.

Step 6: Fix cables using existing cable brackets and mount additional cable ties and adhesive sockets.

ABOUT LEDVANCE

With offices in more than 50 countries and business activities in more than 140 countries, LEDVANCE is one of the world's leading general lighting providers for professional users and end consumers. Having emerged from the general lighting business of OSRAM GmbH, LEDVANCE offers a wide-ranging assortment of LED luminaires for a broad spectrum of application areas, intelligent lighting products for Smart Homes and Buildings, one of the largest LED lamps portfolios in the industry as well as traditional light sources



LEDVANCE

LEDVANCE GmbH
Parkring 29 – 33
85748 Garching
Germany
LEDVANCE.COM

Subject to change without notice. Errors and omission excepted.

LEDVANCE.COM