

1) Sensing surface, 2) Data carrier, 3) Clear zone, 4) Tightening torque



Basic features

Antenna type	round
Approval/Conformity	CE UKCA cULus FCC IC (Radio) WEEE MIC KC NBTC IMDA MCMC
Principle of operation	Read/write device

Display/Operation

Function indicator	Power (ON) Green LED TP (Tag Present) LED yellow
--------------------	---

Electrical connection

Connection	(RS232/TP OUT): M12x1-Male, 8-pin
------------	-----------------------------------

Electrical data

Current consumption max. at 24 V DC	50 mA
Current consumption max., note	no load
Operating voltage U_b	19.2...26.4 VDC
Output current max.	200 mA
Residual ripple max.	included

Environmental conditions

Altitude max.	2000 m
Ambient temperature	0...70 °C
Area of operation	Indoor
Contamination scale	2
Continuous shock load	yes
EN 60068-2-27, Shock	yes
EN 60068-2-32 Free fall	yes
EN 60068-2-6, Vibration	yes
IP rating	IP67
Relative humidity	0...90 %, non-condensing
Storage temperature	-20...85 °C

Functional Characteristics

Supported data carrier types	DIN ISO 14443 DIN ISO 15693
------------------------------	--------------------------------

Functional safety

MTTF (40 °C)	191 a
--------------	-------

Interface

Interface	RS232
Output TP	PNP

Material

Housing material	Brass, Nickel-plated brass nuts, nickel-plated
Housing material, surface protection	nickel-plated

Mechanical data

Application weight	100.00 g
Dimension	Ø 30 x 83 mm
Installation	metal-free (clear zone)
Size	M30x1.5

Remarks

For installation in metal: Observe clear zone.

Values are under rated conditions unless otherwise specified.

Use included nuts for installation.

OUT TP switches to +24V when there is a data carrier in the zone.

* Connection RTS (TP) enables TP display in program BISCOMRW.EXE.

For basic equipment: Accessories see www.balluff.com

This device is intended to be supplied by a UL-listed or CSA-certified power supply unit with "Class 2" or LPS power source.

The devices must be installed permanently.

1. Determine a suitable mounting position.
2. Fasten the device with suitable mounting material.

The device can be cleaned with a slightly damp cloth.

Regularly check the function of the device and all associated components through visual and functional tests.

- Shut down the device in the event of malfunctions.
- Secure the system against unauthorized use.
- Check fastening and tighten if necessary.

The product is maintenance-free.

For more information about MTTF and B10d see MTTF / B10d Certificate

Indication of the MTTF- / B10d value does not represent a binding composition and/or life expectancy assurance; these are simply experiential values with no warranty implications. These declared values also do not extend the expiration period for defect claims or affect it in any way.

Connector Drawings

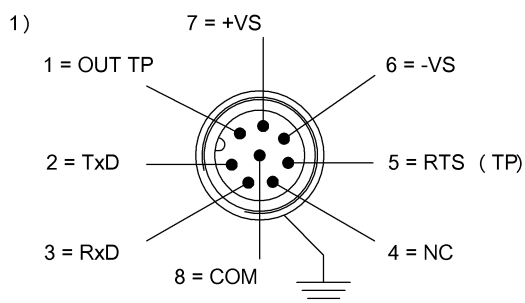

1) View towards connector

Wiring Diagrams

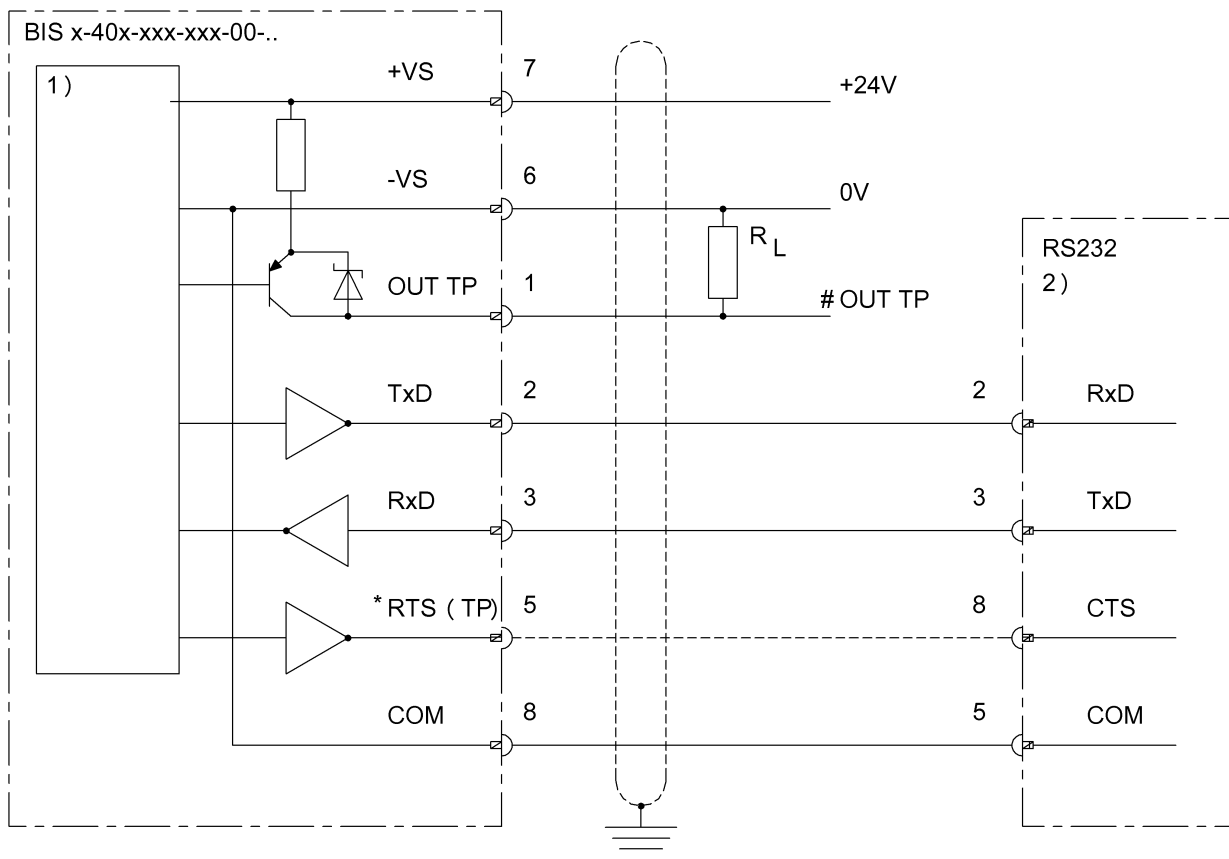

- 1) Internal circuit
- 2) 9-pin connection

Help Views

BIS M-400-XXX-001-__

	BIS M-101-01/L	BIS M-102-01/L	BIS M-105-01/A	BIS M-105-02/A	BIS M-108-02/L
passende Datenträger Appropriate data carriers					
Abstand Datenträger zu Metall in mm (a) Data carrier distance to metal in mm	>25 >10 >5	>50 >15 >10	>20 >5	>20 >5	>25 >0
Freizone Datenträger in mm (b) Data carrier clear zone in mm	>100 >60 >50	>150 >90 >70	>100 >100	>100 >100	>100 >0
Schreibabstand in mm Write distance in mm	0-20 0-15 0-12	0-28 0-20 0-12	0-7 0-6	0-11 0-7	0-28 0-16
Leseabstand in mm Read distance in mm	0-20 0-15 0-12	0-28 0-20 0-12	0-7 0-6	0-11 0-7	0-28 0-16
Versatz in mm bei Abstand von	0 ±14 1 ±10 ±6	0-20 ±15 ±6	±7 ±6	±9 ±6	±16 ±10
	5 ±14 ±10 ±6	±20 ±15 ±6	±7 ±6	±8 ±6	±16 ±10
	9 ±14 ±8 ±4	±20 ±15 ±3		±5	±14 ±8
	12 ±10 ±4 ±2	±20 ±13 ±2			±14 ±6
	15 ±10 ±2	±20 ±10			±14 ±6
	16 ±8	±18 ±3			±14 ±4
	18 ±6	±16			±14
	20 ±5	±15			±14
	22	±15			±12
	25	±10			±12
	30				
	32				
	35				
	40				
	43				
	45				
	50				
	52				
	60				
	65				
	70				

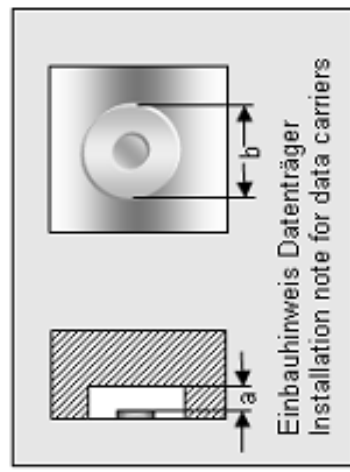

BIS M-400-xxx-001-

	BIS M-110-02/L	BIS M-111-02/L	BIS M-112-02/L	BIS M-132-03/L-HT	BIS M-135-03/L-HT
passende Datenträger Appropriate data carriers					
Abstand Datenträger zu Metall in mm (a) Data carrier distance to metal in mm	>25 >10 >5	>25 >10 >5	>50 >15 >10	>25 >0	>50
Freizone Datenträger in mm (b) Data carrier clear zone in mm	>100 >60 >50	>100 >60 >50	>150 >90 >70	>100 >100	>150
Schreibabstand in mm Write distance in mm	0-20 0-15 0-8	0-28 0-18 0-10	0-38 0-25 0-15	0-30 0-8	0-42
Lesabstand in mm Read distance in mm	0-20 0-15 0-8	0-28 0-18 0-10	0-38 0-25 0-15	0-30 0-8	0-42
Versatz in mm bei Abstand von	0 ±12 ±8 ±6	±16 ±10 ±7	±22 ±16 ±13	±18 ±8	±30
	5 ±12 ±8 ±5	±16 ±10 ±7	±22 ±16 ±13	±18 ±8	±30
	7 ±10 ±6 ±4	±14 ±8 ±2	±22 ±14 ±10	±18 ±6	±30
	8 ±10 ±6 ±2	±14 ±8 ±2	±22 ±14 ±10	±18 ±3	±30
	9 ±10 ±6	±14 ±8 ±2	±22 ±14 ±10	±18	±30
	10 ±8 ±4	±14 ±7 ±1	±20 ±13 ±8	±18	±30
	12 ±8 ±4	±14 ±7	±20 ±13 ±8	±18	±28
	15 ±8 ±2	±14 ±6	±20 ±12 ±6	±18	±28
	16 ±5	±14 ±3	±20 ±10	±18	±28
	18 ±5	±14 ±2	±20 ±10	±18	±28
	20 ±5	±14	±20 ±8	±18	±28
	22	±12	±20 ±6	±16	±24
	25	±12	±20 ±4	±16	±24
	30		±16	±5	±24
	32		±10		±24
	35		±10		±24
	38		±5		±5
	42				±5
	45				
	50				
	55				

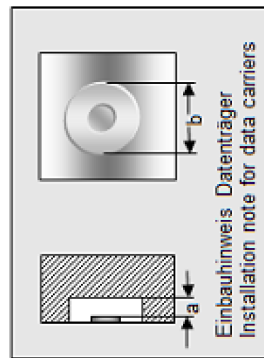

BIS M-400-XXX-001-__

passende Datenträger Appropriate data carriers	BIS M-107-03/L- H200	BIS M-140-02/A- XX	BIS M-142-02/A- XX	BIS M-143-02/A- XX	BIS M-144-02/A- XX
Abstand Datenträger zu Metall in mm (a) Data carrier distance to metal in mm	>25	>0	>0	>0	>0
Freizone Datenträger in mm (b) Data carrier clear zone in mm	>100	>100	>100	>100	>100
Schreibabstand in mm Write distance in mm	0-27	0-22	0-22	0-13	0-22
Leseabstand in mm Read distance in mm	0-27	0-13	0-22	0-13	0-22
Versatz in mm bei Abstand von	0 5 10 13 15 18 20 22 25 27	±16 ±10 ±10 ±7 ±5	±13 ±13 ±13 ±11 ±11 ±11 ±7 ±7	±13 ±10 ±10 ±9 ±5	±13 ±13 ±13 ±11 ±11 ±11 ±7 ±7
Offset in mm at distance	30 32 35 40 43 45 50 52 60 65 70	±5			

