

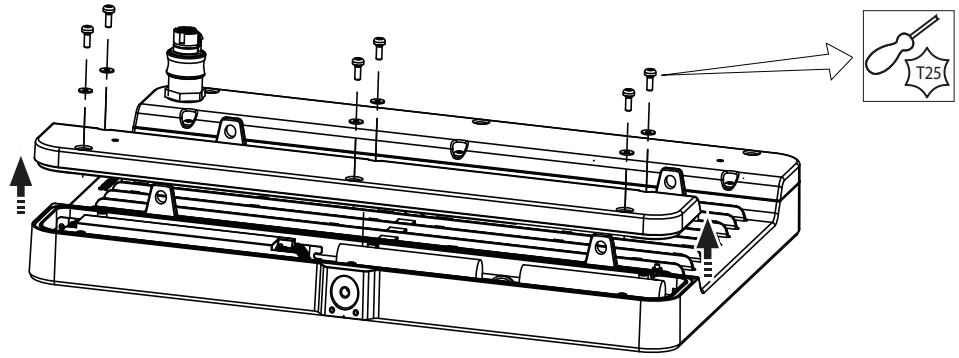

BY481P Emergency versions

Battery replacement

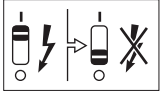

1

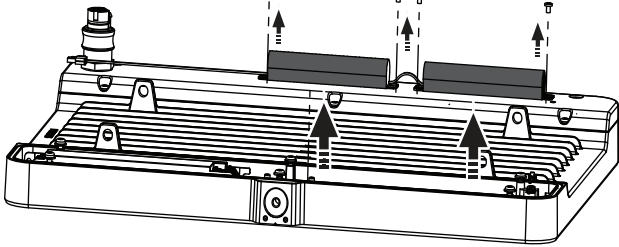

2



Plastic washers must be replaced!

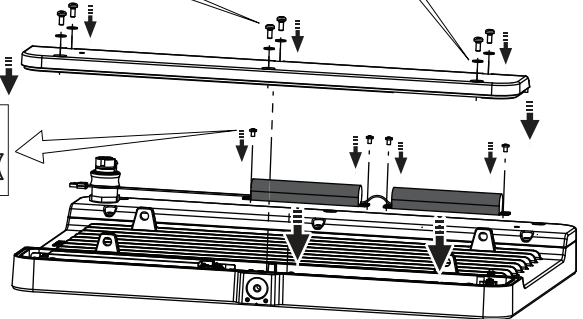

3

Rated light output in emergency operation mode: ELD3, ELP3 - 850 lm

WB

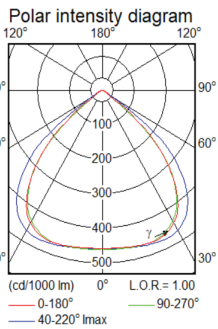

MB

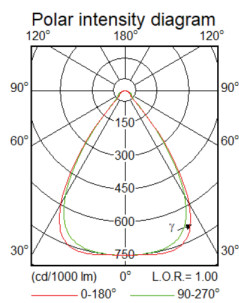

NB

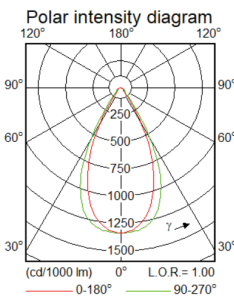

XNB

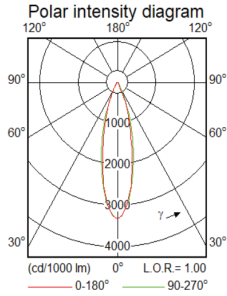

HRO

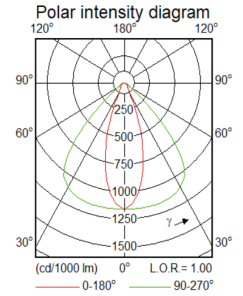

Charge time



→ 24.00 →



Lifetime

The batteries have a life time expectancy of 4 years when maintained properly. Replace after that time!

Functional Notice for Emergency Lighting

Automatic emergency time selection

After installation and power up the driver will detect the battery and start the automatic detection process.

- During automatic detection, the indicator LED will light up with short green flashes.
- Between minimum 6 and maximum 30 seconds the TrustSight driver will set the battery type (number of cells) and will set the emergency output power accordingly.



After that, the system is defined and fully operational. The battery type definition has influence on the performance during the self-test and on the battery charge method. When the automatic battery detection process is disrupted, e.g. by switching off the permanent mains, the detection process is stopped and the TrustSight emergency driver will go into emergency mode with the lowest output power. At a next power up, the automatic detection process will start again.

Periodic testing

Periodic tests of emergency lighting luminaires must be performed according to EN50172 clause 7.2.3 and 7.2.4. Switch on in the emergency mode each month by simulation of a failure of the supply to the normal lighting for a period sufficient to ensure that each lamp is illuminated. Twice per year, each luminaire shall be tested for its full rated duration (at least 3hrs).

For more information please consult the TrustSight Gen 3 Design in guide. The latest version is available online.

LED indicator status

LED indicator (color / flashing)	Error condition	Cause	Solution
Green / no flashing		System OK, battery fully charged	
Off		Mains off, EM mode, Rest mode, test in progress	
Green / slow (0.25s on, 1.25s off)		System OK, battery is charging	
Green / fast (0.25s on, 0.25s off)		System OK, recently tested (< 5 days, Australia mode only)	
Red / no flashing	Battery voltage too high or too low	No battery connected	Connect battery
		Wrong or bad battery connected	Replace battery
Red / fast (0.25s on, 0.25s off)	Output voltage too low or too high	Wrong LED load connected	Connect right load and perform functional test
	No load connected or output shorted	Wrong connection	Connect right load and perform functional test
Red / slow (0.25s on, 1.25s off)	Failed test due to battery	Battery end of life	Replace battery and perform duration test.
		Charger failure	Replace driver
Red-green / fast		DALI device identification	
Fast flashing: (on-time = 0.25s, off-time = 0.25s) Slow flashing: (on-time = 0.25s, off-time = 1.25s)			
Green / short on-time = 50ms, off-time = 0.95s)		Battery detection	

Emergency Luminaires

In case a self-contained emergency driver has been added, this is how to set the timers (IEC62034 (§6.3.2)):

DALI version: Check IEC 62386 part 202.

PRO version: The first test is randomized. Then a fixed schedule is maintained, there is no need to set the timers or take special precautions when powering

BASIC version: No timers available, only manual testing through the test button.