

# PHILIPS

## FlexBlend Surface-Mounted, Suspended

SM340C  
SP340P



### SUSPENDED

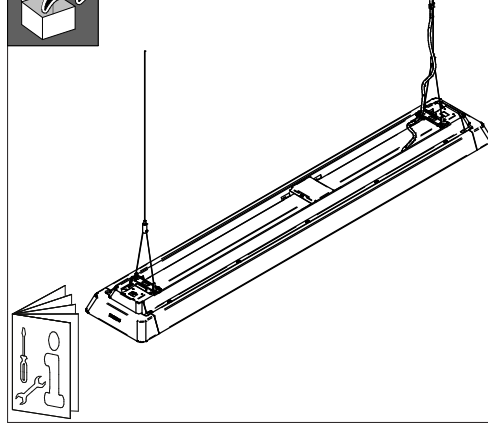

### SURFACE-MOUNTED

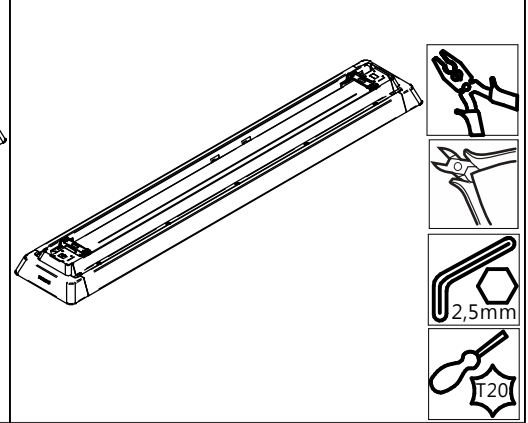

Glow Wire MLO 650°C PCS/OPAL 850°C	FAMILY NAME	FAMILY CODE	Dimensions ( mm )						kg	
			A	B	C	D	D min	D max		
	SURFACE-MOUNTED	SM340C stand alone	1200	200	73	1000	940	1030	4,3	
			1470			1270	1210	1300	5,2	
		SM341C line	1081	200	73	1000	940	1030	4,0	
			1352			1270	1210	1300	4,9	
		SUSPENDED	SP340P suspended direct stand alone	1200	200	73	1000	940	1030	4,5
				1470			1270	1210	1300	5,4
	SP341P suspended direct line		1081	200	73	1000	940	1030	4,3	
			1352			1270	1210	1300	5,2	
	SP342P suspended direct/indirect stand alone		1200	200	73	1000	940	1030	4,7	
			1470			1270	1210	1300	5,5	
	SP343P suspended direct/indirect line	1081	200	73	1000	940	1030	4,5		
	1352	1270			1210	1300	5,3			

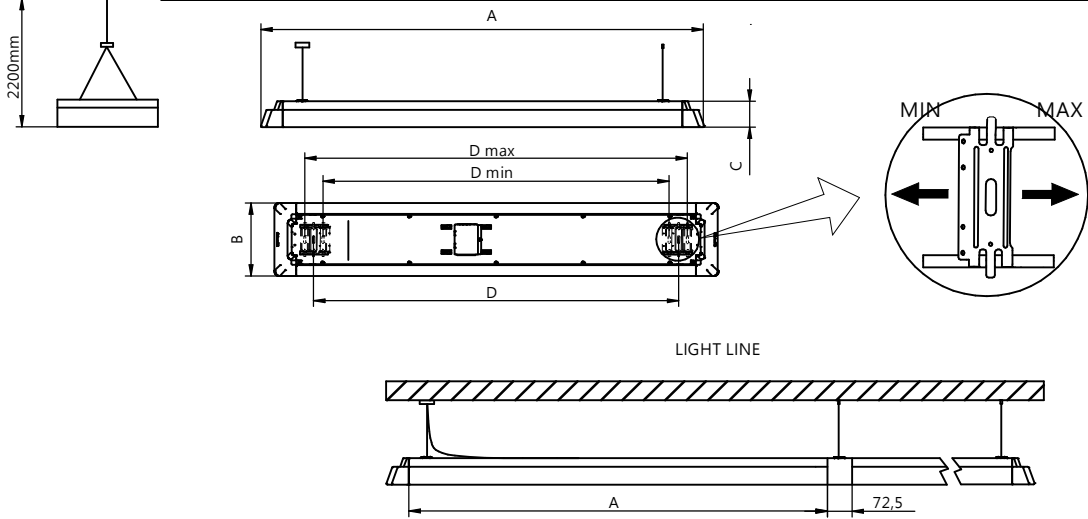

Accessories														
SP340Z CP...	-	-	-	-	-	8	-	-	0,75mm <sup>2</sup>	-	1	1	-	-
SP340Z EP...	-	-	-	-	-	-	-	-	-	-	-	1	-	-
SP340Z SMTE L1500	1	1	2	1	2	6	-	1	2	-	-	-	4	1
SP340Z SMT L1500	1	1	2	1	2	6	-	-	2	-	-	-	4	1
SP340Z SMTTE L1500	-	-	2	1	2	6	2	1	2	-	-	-	4	1
SP340Z SMIT L1500	-	-	2	1	2	6	2	-	2	-	-	-	4	1
SP340Z SW2T L1500	-	-	2	1	-	-	-	-	2	-	-	-	4	1
SP340Z SW2T CONC L1500	1	1	2	1	-	-	-	-	2	-	-	-	4	1

**SUSPENDED**

- SP340Z SMTE L1500
- SP340Z SMT L1500
- SP340Z SMITTE L1500
- SP340Z SMITT L1500
- SP340Z SW2T L1500
- SP340Z SW2T CONC L1500

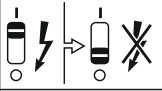

- SP340Z SMITE L1500
- SP340Z SMITT L1500

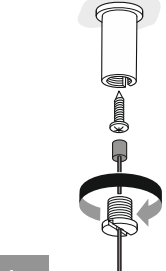

1a

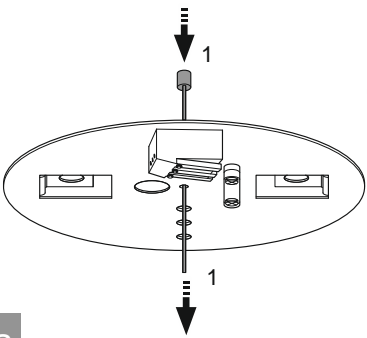

2a

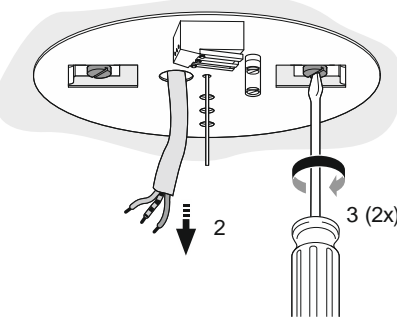

1b

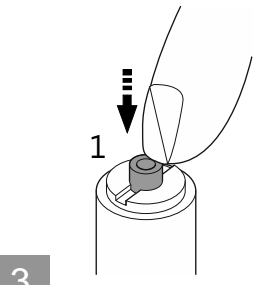
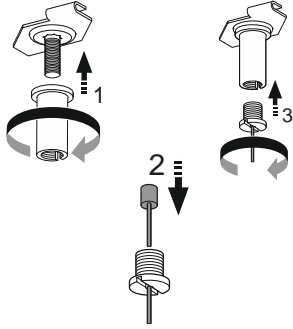

3

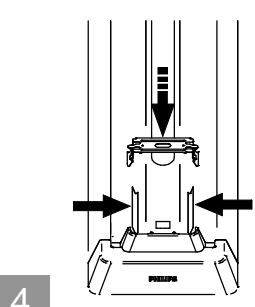
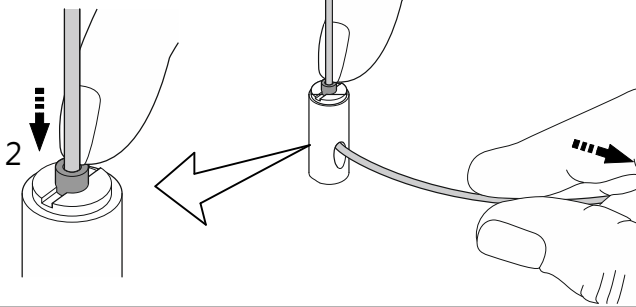

4

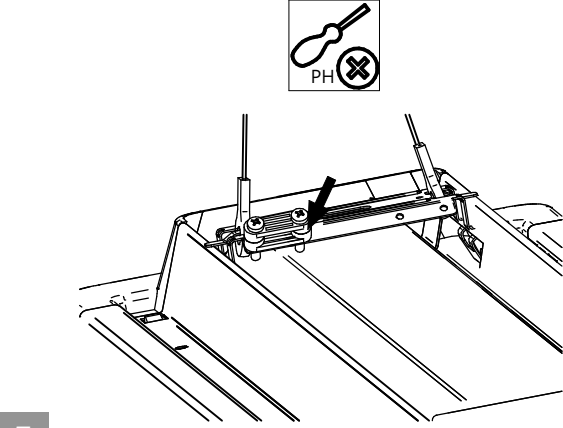
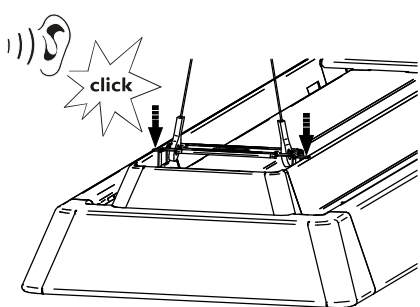
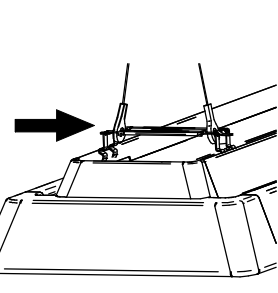
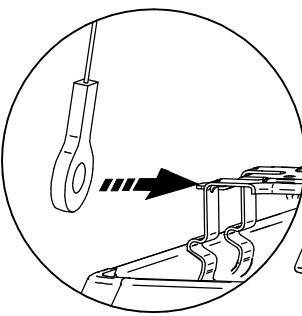

5

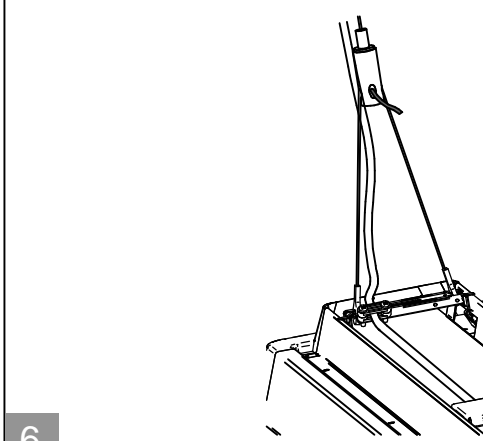

6

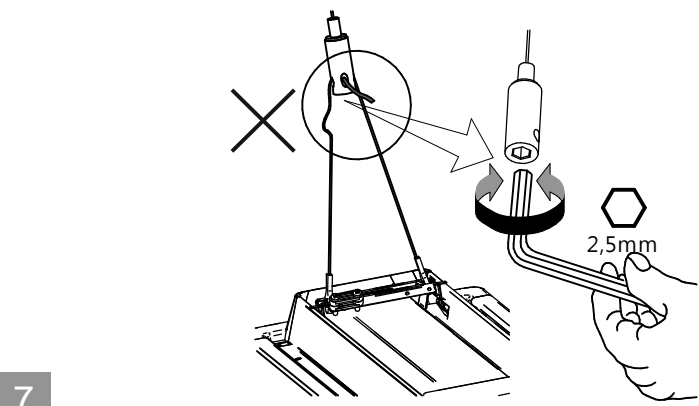

7

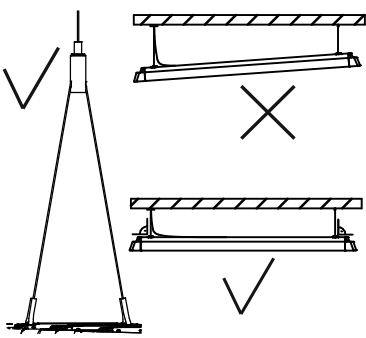

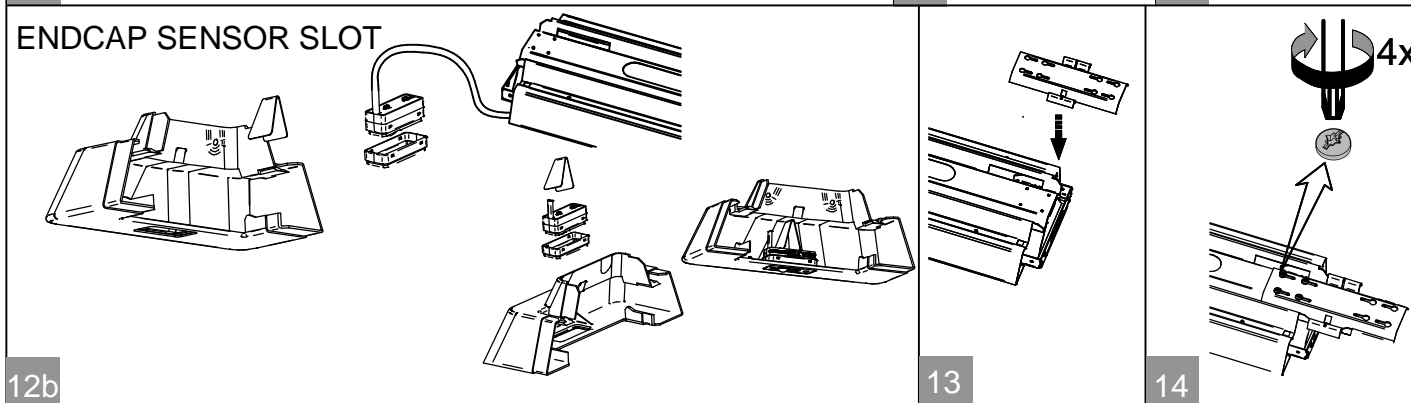
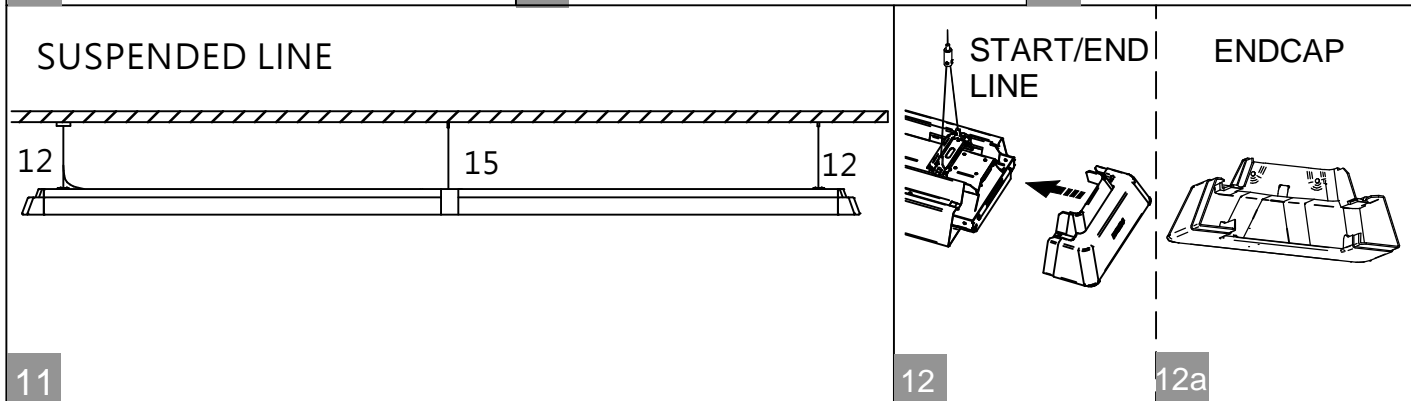
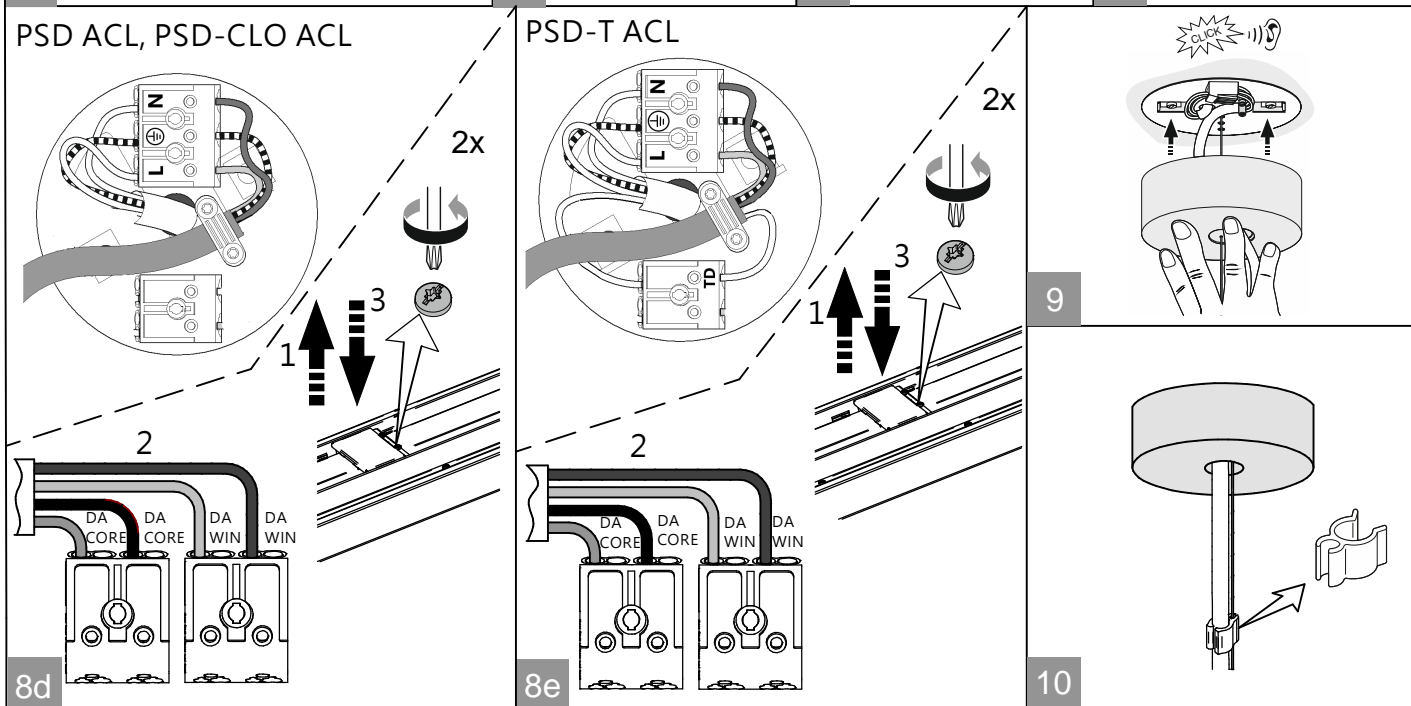
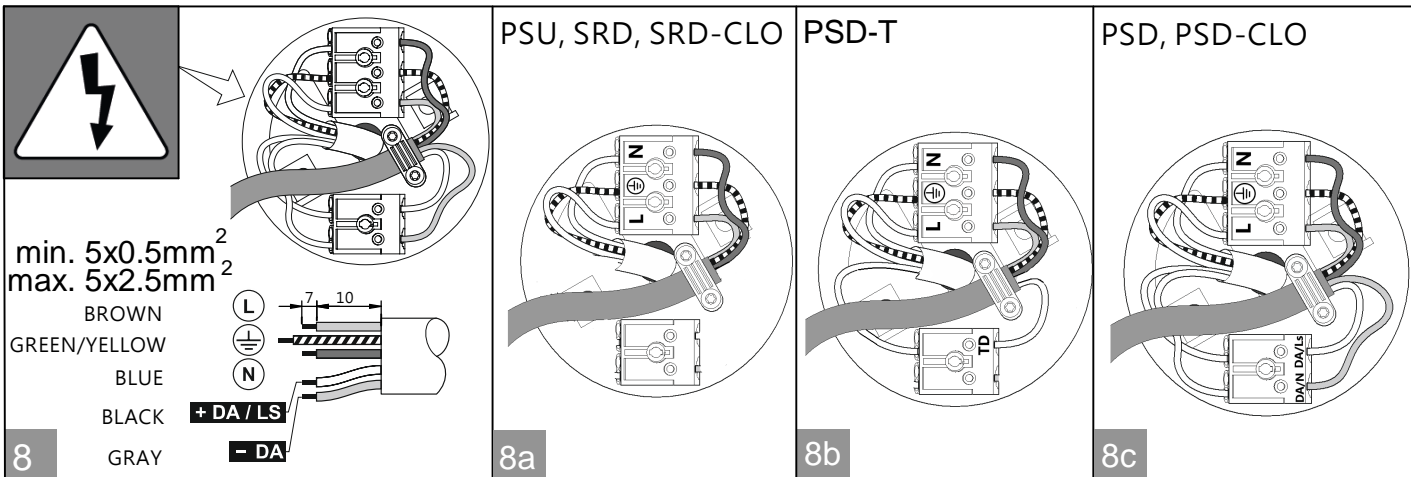

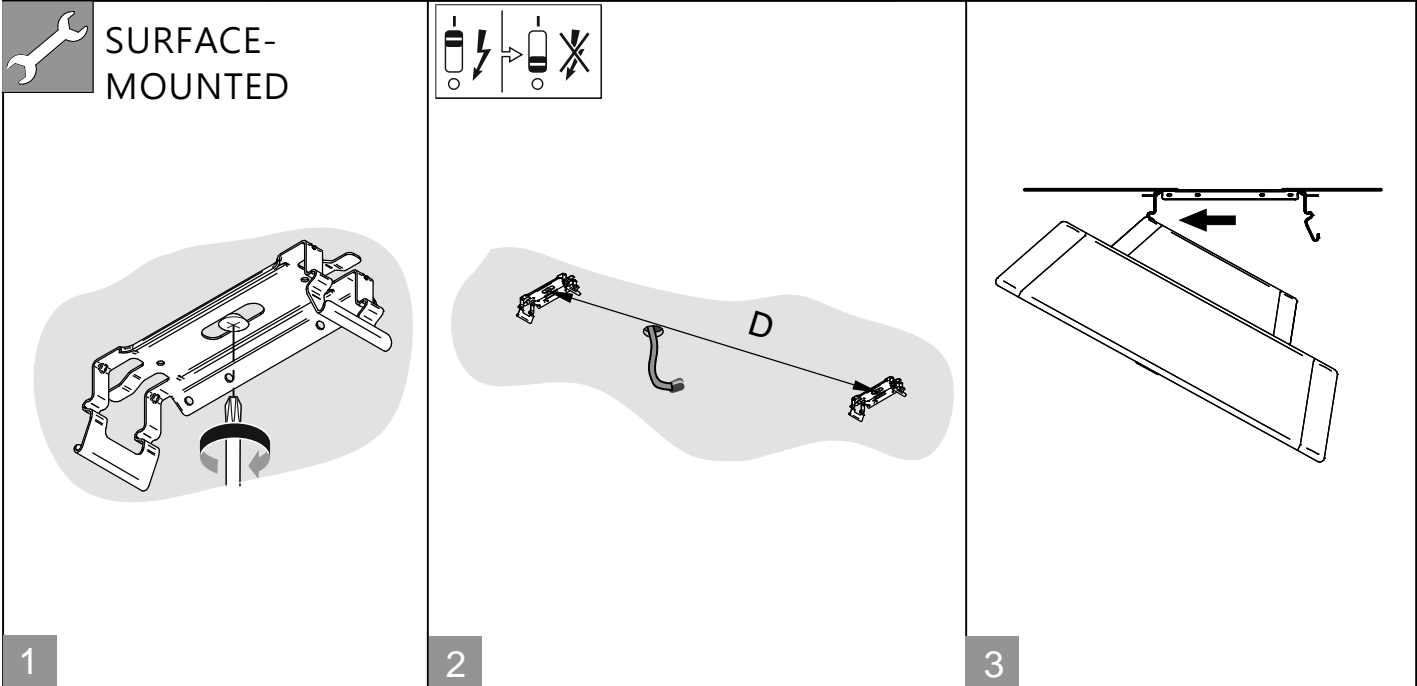
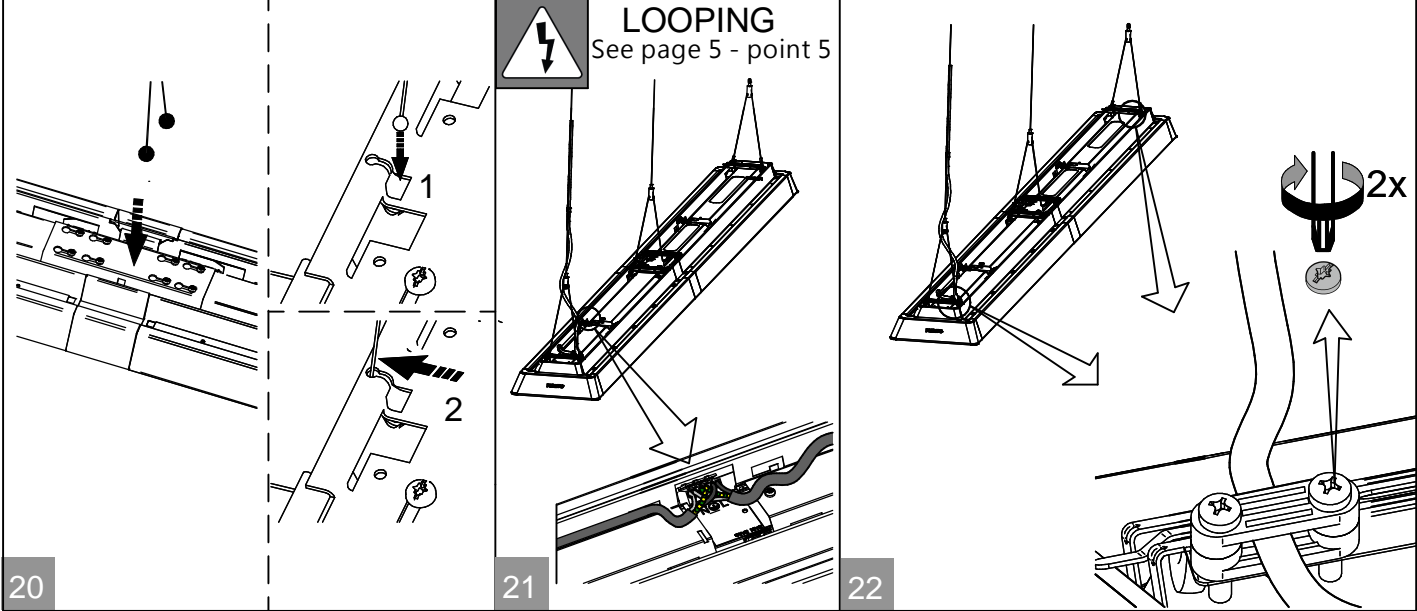
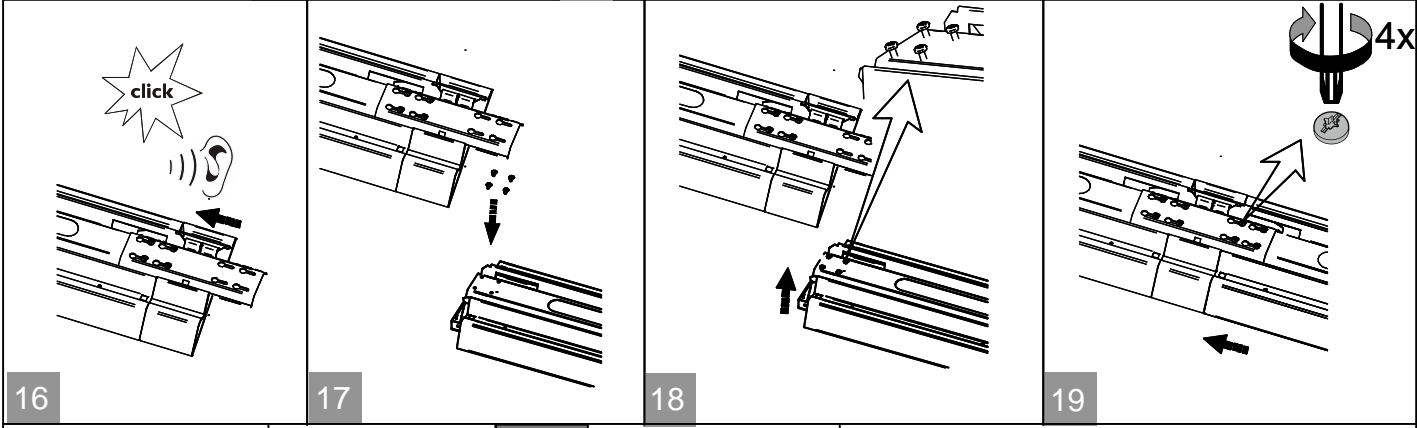
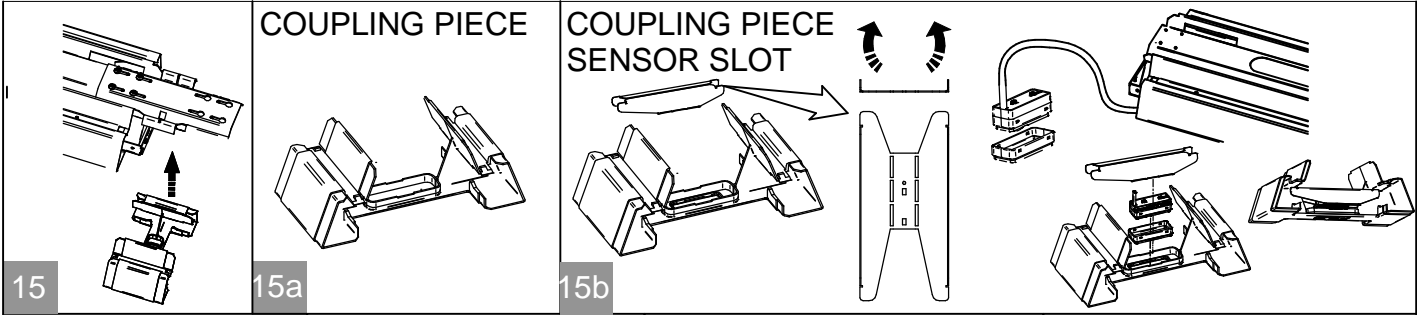

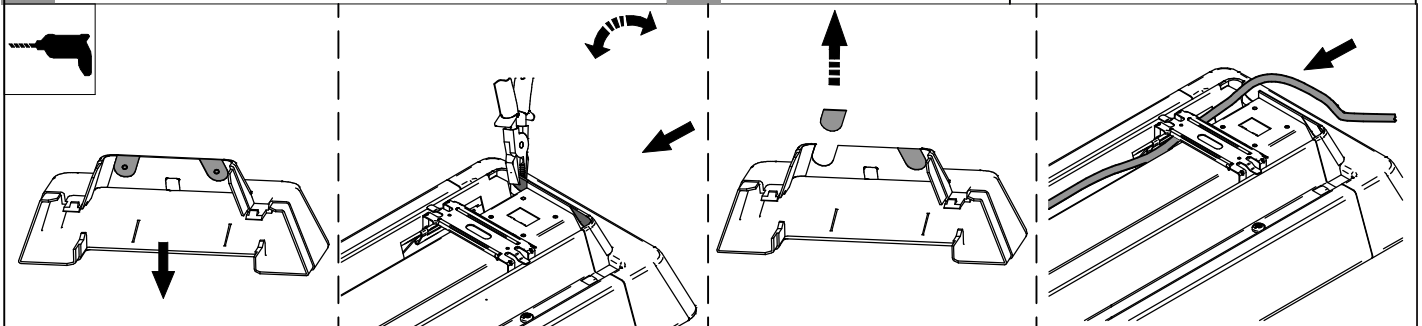
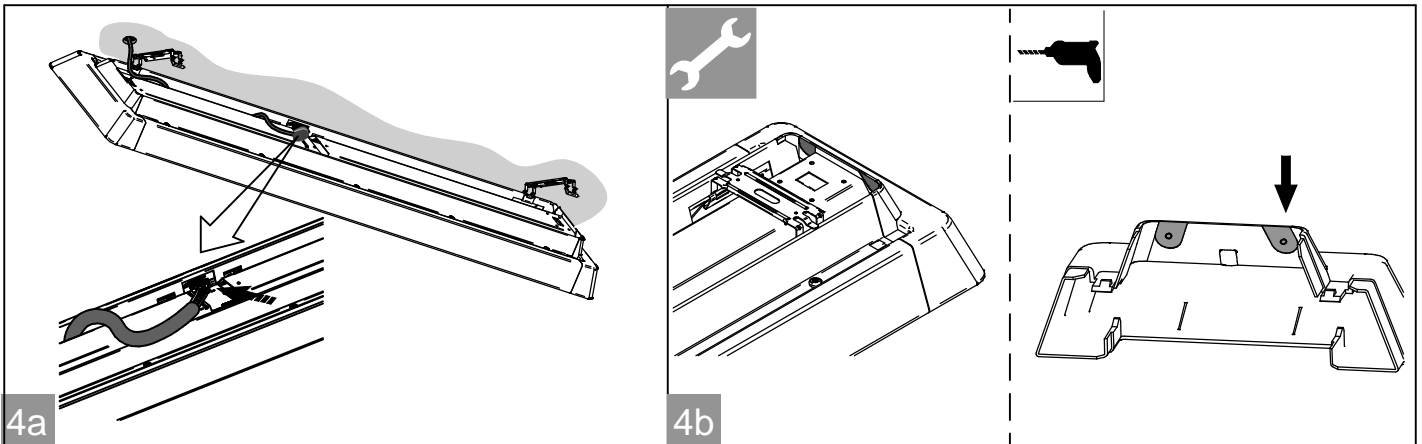

**5**

**min. 5x0.5mm<sup>2</sup>  
max. 5x2.5mm<sup>2</sup>**

BROWN (L)  
GREEN/YELLOW (⊕)  
BLUE (N)  
BLACK (+DA/LS)  
GRAY (-DA)

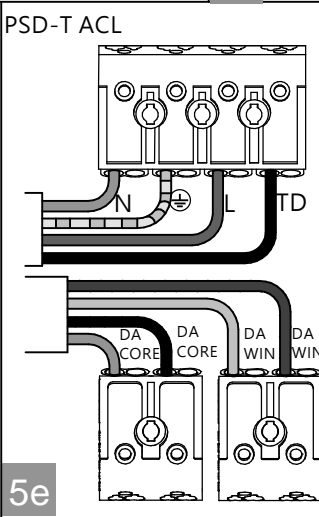
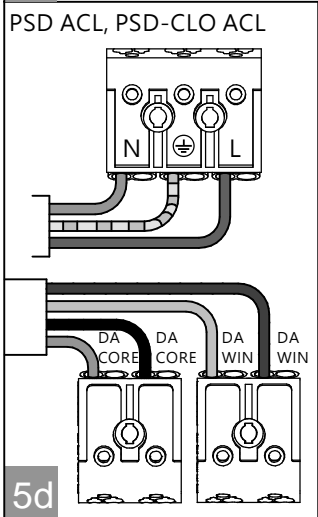
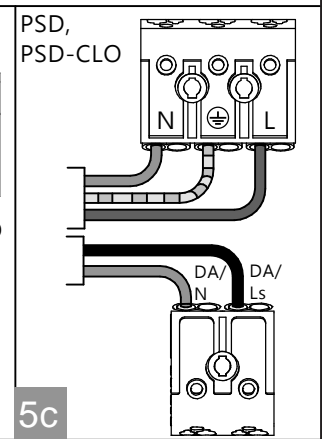
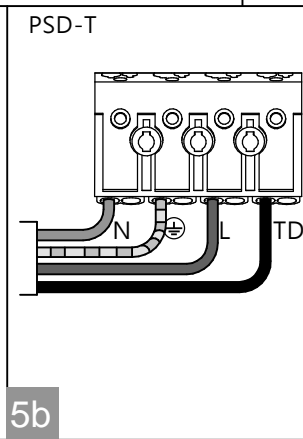
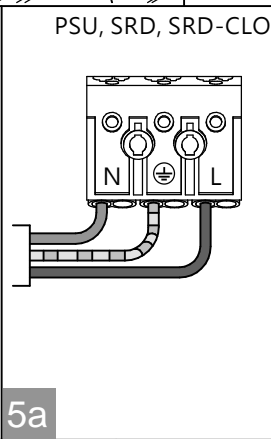

**5f**

**Interact Office Wired (PoE)**

Condition Philips to specify to the customers (instruction):  
 > to use UTP (Unshielded Twisted Pair) CAT5E or CAT6 cable  
 > the maximum length of the cable to be 20 meters.  
 Apply a minimum radius of the Ethernet cable of 4x the cable diameter.

min. 7mm

RJ45

click

**SpaceWise (SWZU)**  
 More information on installing and commissioning of SpaceWise:

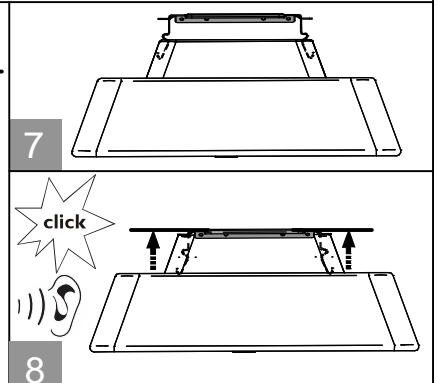
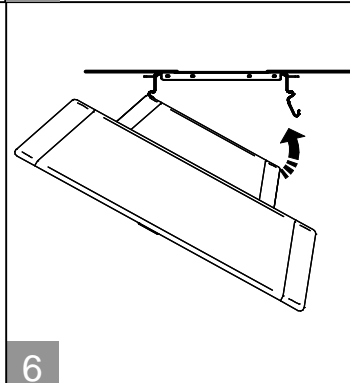

SURFACE LINE

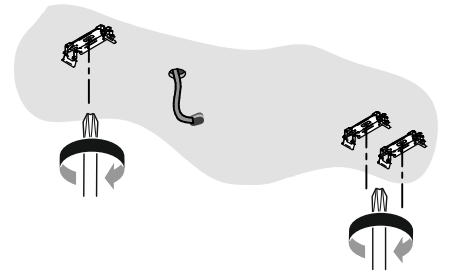
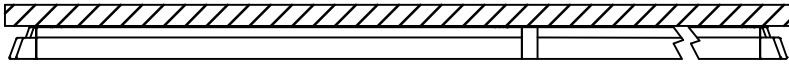

1

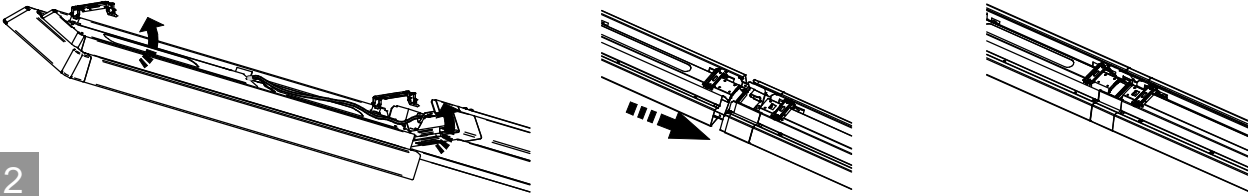

2

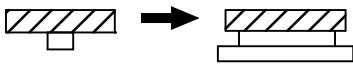

change from SM to SP

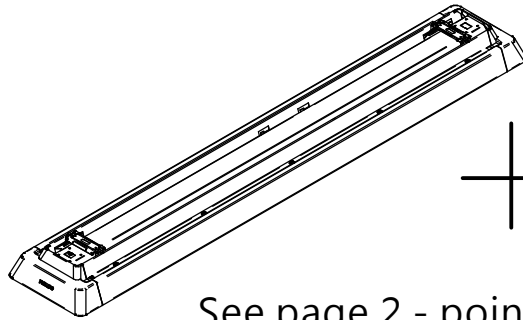
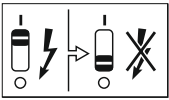

Suspension accessories

SP340Z SMTE L1500
SP340Z SMT L1500
SP340Z SMTE L1500
SP340Z SMTT L1500
SP340Z SW2T L1500
SP340Z SW2T CONC L1500

3

See page 2 - points from 1a to 7



Change from SP to SM

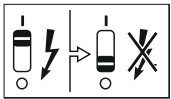

See page 5 - point 5

BROWN (L) 7-10  
 GREEN/YELLOW (⊕)  
 BLUE (N)  
 BLACK (+ DA / LS)  
 GRAY (- DA)

min. 5x0.5mm<sup>2</sup>  
max. 5x2.5mm<sup>2</sup>

4

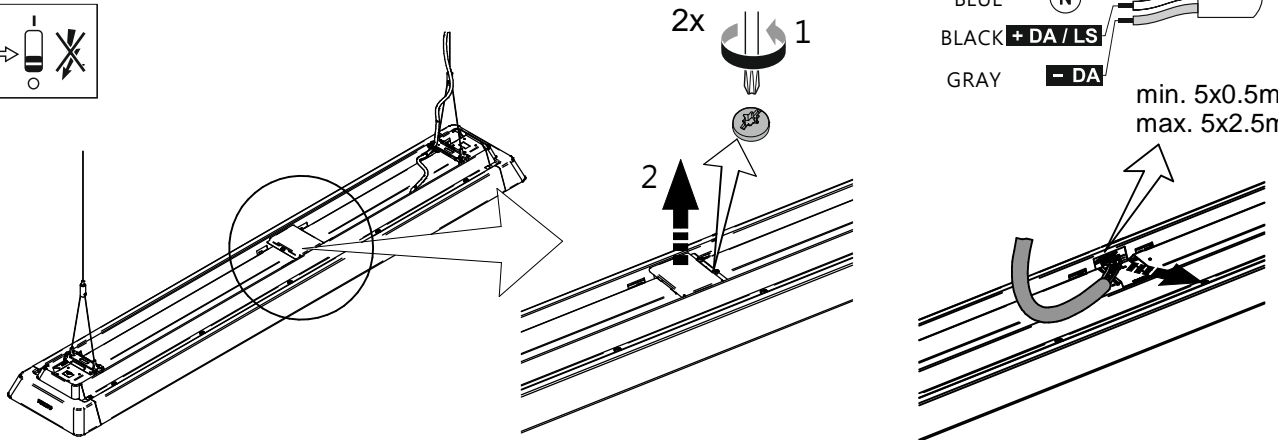

5

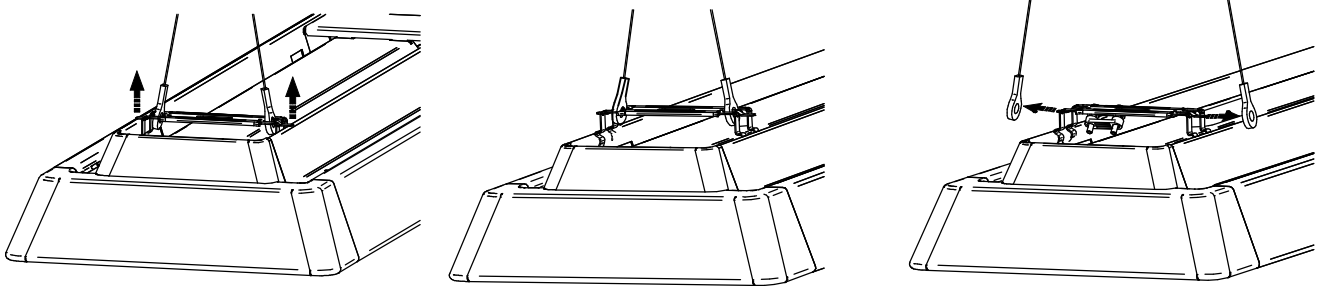

6

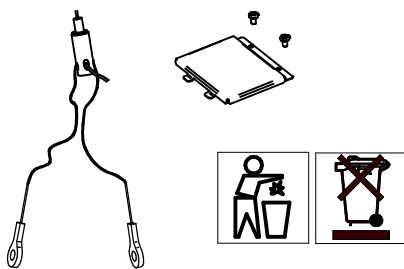



# DRIVER EXCHANGE

2x

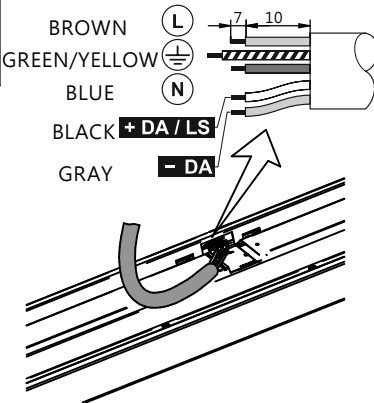
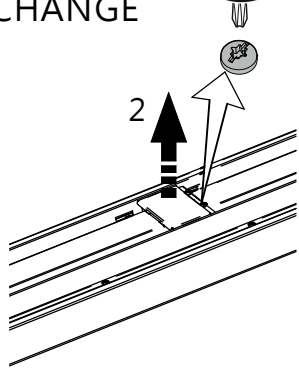

2x

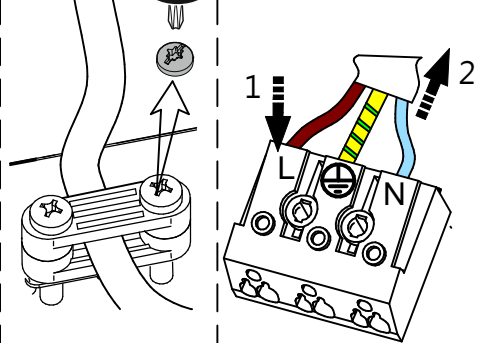

1

2

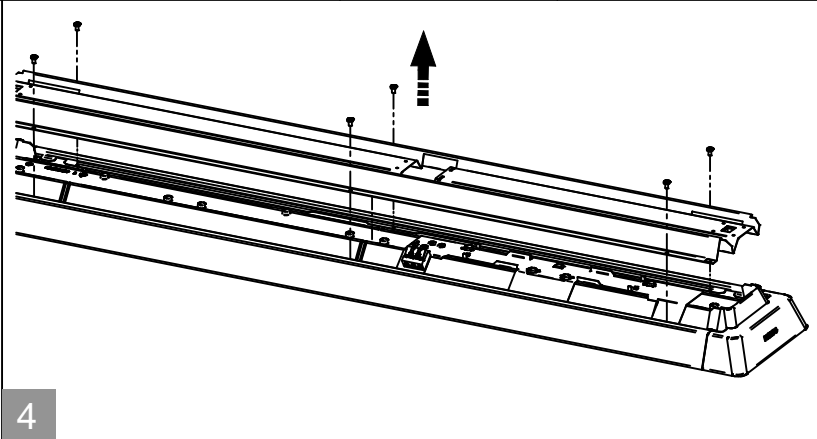
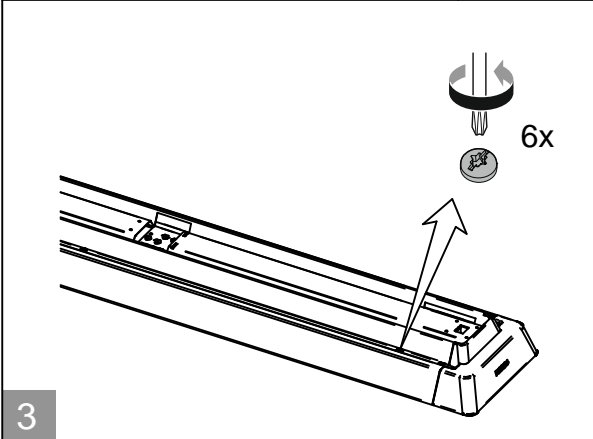

3

4

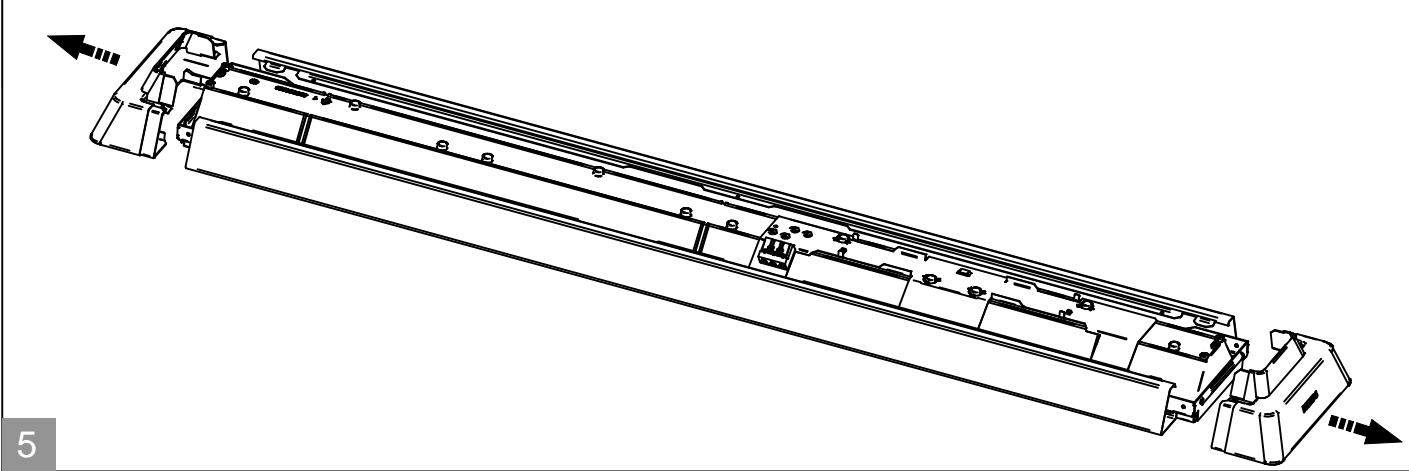

5

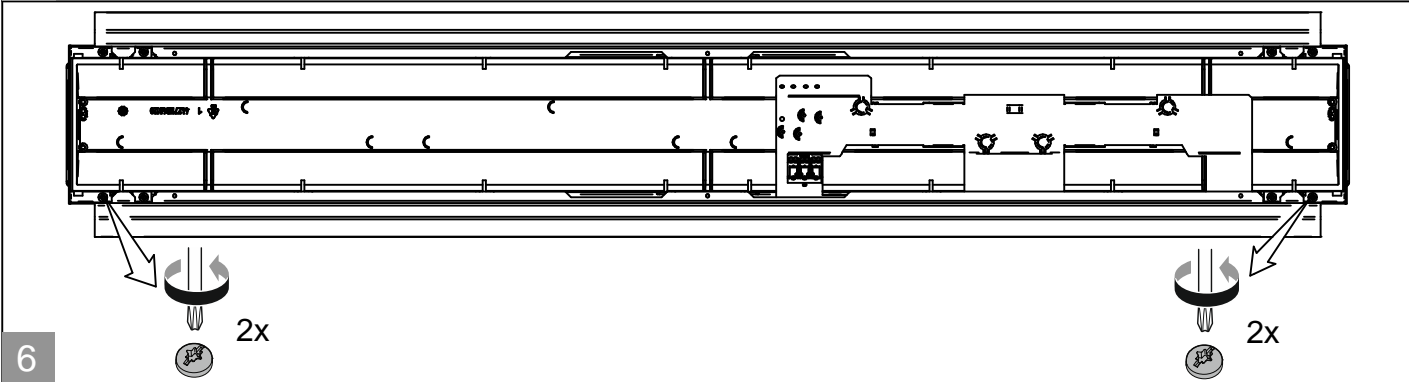

6

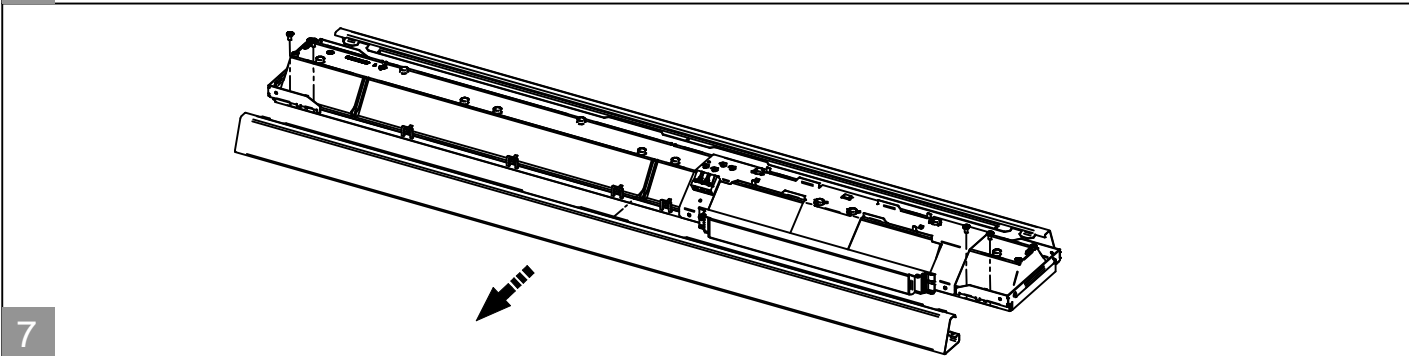

7

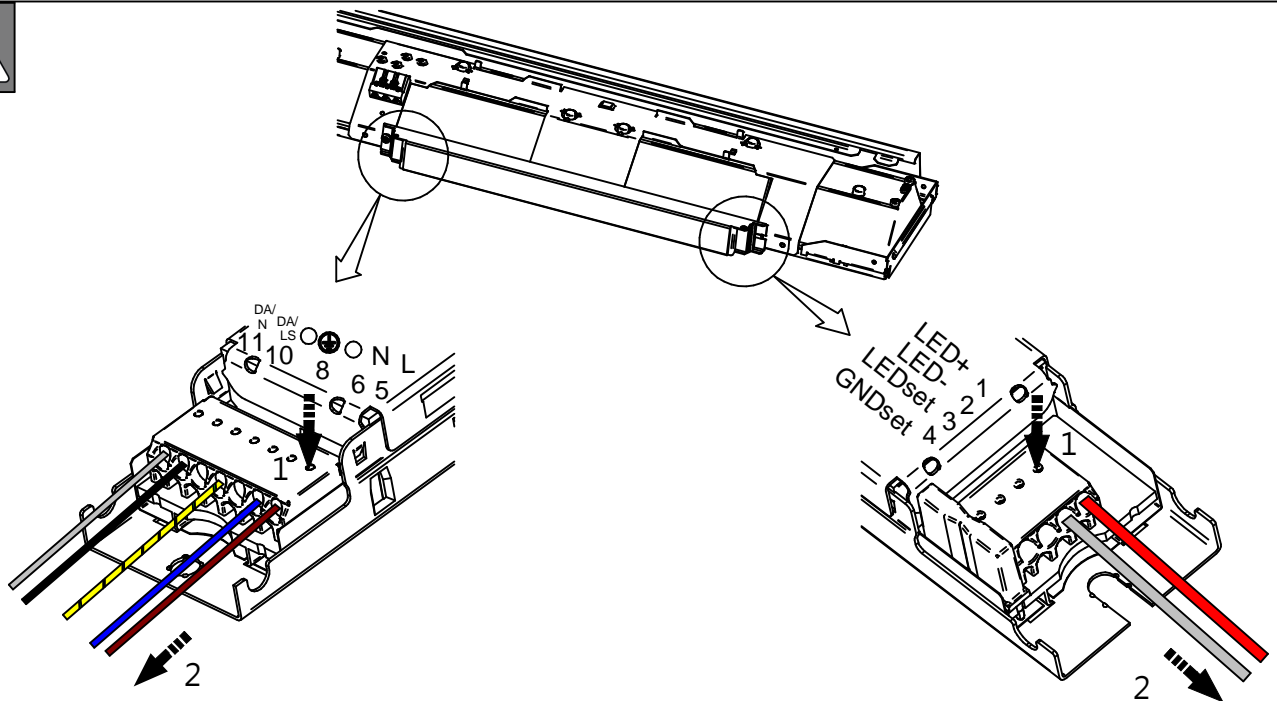

8

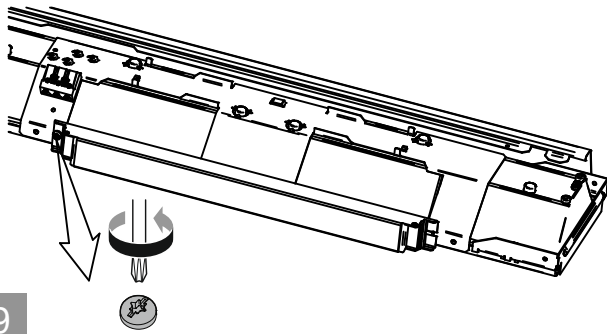

9

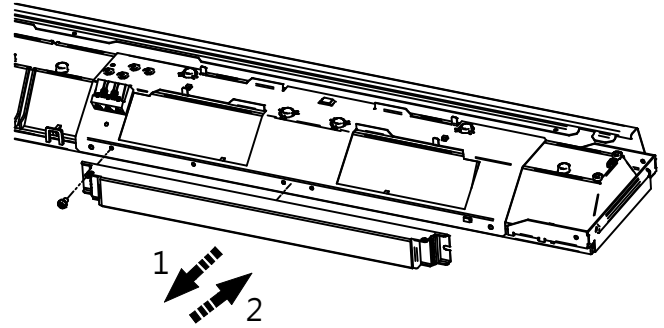

10

After replacing the driver, reassemble the luminaire in the reverse order



### LIGHT MODULE EXCHANGE

SEE POINTS 1 to 8 PAGE 7

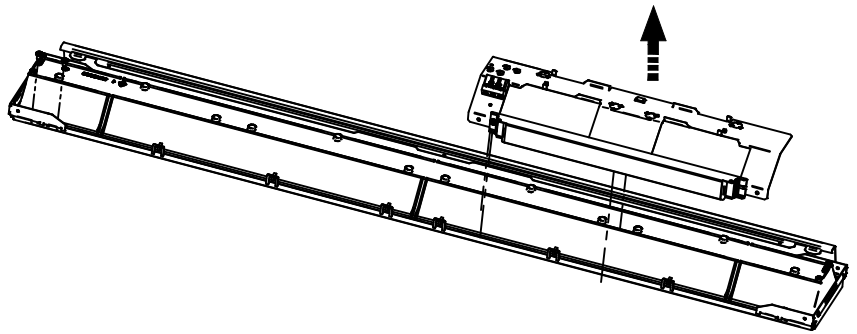

1

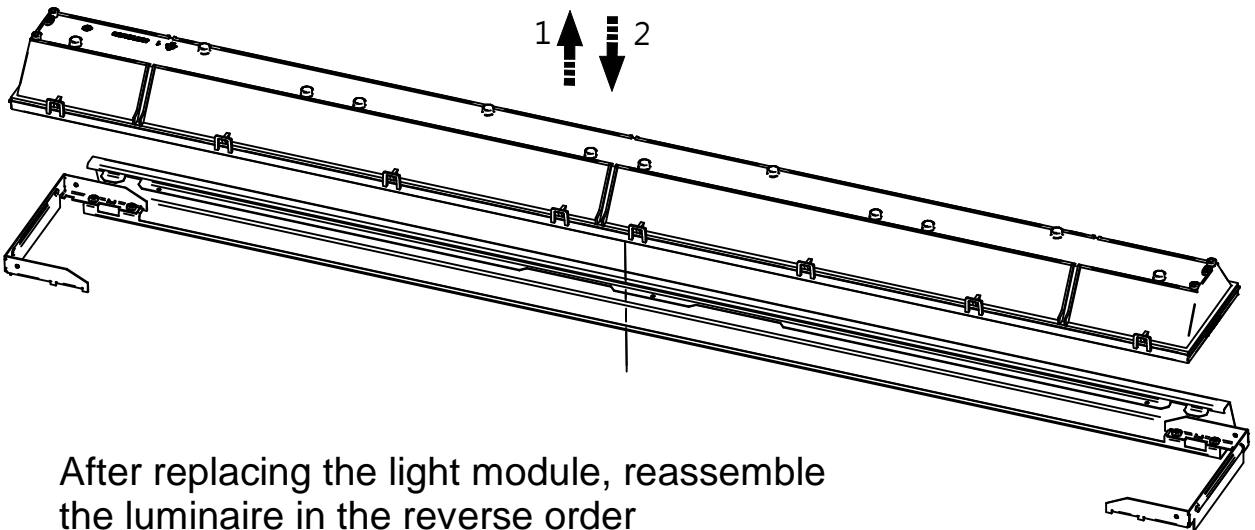

2

After replacing the light module, reassemble the luminaire in the reverse order



## Inrush current

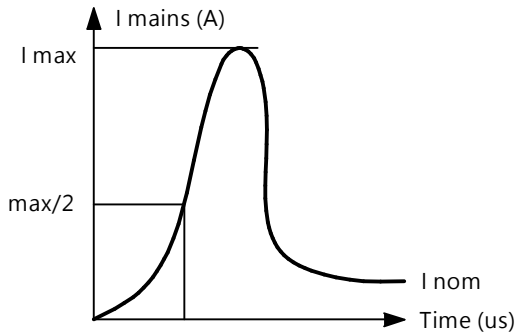

## ELECTRICAL CHARACTERISTICS

DRIVER		CABLE		No. of Luminaires per MCB										
TYPE	I <sub>max</sub> [A]	T <sub>ref</sub> [μs]	Cores [-]	C.Section [mm <sup>2</sup> ]	B-6A	B-10A	C-10A	B-13A	C-13A	B-16A	C-16A	B-20A	C-20A	
PSU	17,8	282	3 - 5	0,75	9	15	15	15	15	15	15	15	15	
PSD	25,1	214			8	13	15	15	15	15	15	15	15	15
SRD	21	280			7	11	15	14	15	15	15	15	15	15
PSU	17,8	282	3 - 5	1	9	15	25	19	24	24	25	25	25	
PSD	25,1	214			8	13	21	17	24	21	25	25	25	
SRD	21	280			7	11	18	14	24	18	25	22	25	
PSU	17,8	282	3 - 5	1,5	9	15	23	19	32	24	40	30	40	
PSD	25,1	214			8	13	21	17	28	21	35	26	40	
SRD	21	280			7	11	18	14	24	18	30	22	37	
PSU	17,8	282	3 - 5	2,5	9	15	25	19	32	24	40	30	48	
PSD	25,1	214			8	13	21	17	28	21	35	26	43	
SRD	21	280			7	11	18	14	24	18	30	22	37	

### Maintenance instructions

To assure the lighting quality of this unique LED lighting concept there are a few instructions regarding the maintenance of this LED luminaire:

- Do not touch electronic components!  
Electronic components are under high voltage.  
Electronic components are ESD sensitive.
- During installation or when maintaining the luminaire please use static free gloves to avoid marks on the luminaire.
- To remove dirt and spots use the following:
  - Dust: only use micro fiber cloths
  - Fingerprints, etc.: use a cleaner for synthetic materials with antistatic properties.
- Do not stare into the LED light beam.
- To avoid scratches and dirt on optical parts remove protective foil after installation.
- The luminaire shall be installed by a qualified electrician and wired in accordance with the latest IEE electrical regulations or the national requirements.
- The lightsource is not replaceable. In case of damage replace the luminaire.
- Driver insulation: Basic according to IEC 61847-1

